

SiteSync IQ[®] Wireless System Installation & Operation Manual

H004095_R37 09.2024



Synchronized Time
Made Simple.



american time[®]

Responsible Party: American Time, 140 3rd St. S., PO Box 707, Dassel, MN 55325-0707 USA

TEL: 320-275-2101, declares that the product(s):

SiteSync IQ System Controller and Analog Clocks

Comply with Part 15 of the FCC Rules. Operation is subject to the following two conditions:

- 1) This device may not cause harmful interference
- 2) This device must accept any interference received, including interference that may cause undesired operation

This equipment has been tested and found to comply with the limits for a Class B digital device, pursuant to Part 15 of the FCC Rules. These limits are designed to provide reasonable protection against harmful interference in a residential installation. This equipment generates, uses and can radiate radio frequency energy and, if not installed and used in accordance with the instructions, may cause harmful interference to radio communications. However, there is no guarantee that interference will not occur in a particular installation. If this equipment does cause harmful interference to radio or television reception, which can be determined by turning the equipment off and on, the user is encouraged to try to correct the interference by one or more of the following measures:

- Reorient or relocate the receiving antenna
- Increase the separation between the equipment and receiver
- Connect the equipment into an outlet on a circuit different from that to which the receiver is connected
- Call the dealer or an experienced radio/TV technician for help

FCC Licensing

The SiteSync IQ System can be furnished with a wireless transmitter, either internal to the System Controller or as an external unit. In the USA, these Radio Frequency (RF) transmitters operate in the licensed UHF business band at 450 to 470 MHz. Systems with RF transmitters (internal 5 or 10 watt in the SiteSync IQ System Controller, or 25 watt and higher in the external transmitter) need to be licensed. For USA customers, American Time offers the use of a shared nationwide FCC license, call sign WQFW336. In the USA and its territories, this allows nationwide wireless system operation on the following 5 frequencies up to 100 watts of power, except near the Canadian border*:

FCC AND INDUSTRY CANADA APPROVALS			
SiteSync IQ Equipment	Transmitter FCC ID	Industry Canada Transmitter ID	Industry Canada Receiver ID
Master (5 & 10W internal)	AIERIT33-46009	1084A-RIT3346009	8306A-SSIQ
Master (30W external)	AIERIT34-4650	N/A	8306A-SSIQ
Secondary Wall Clocks	N/A	N/A	8306A-SSIQ

464.600 MHz 464.625 MHz 464.650 MHz 464.675 MHz 464.700 MHz

If you wish to use an existing license in the 450-470 MHz band, or obtain a fixed license for your site, please contact American Time.

*This shared nationwide license is limited to 5 watts power North of Line A and East of Line C, as defined by a treaty with Canada.

Safety Precautions

All electrical power and signal wiring connected to the SiteSync IQ System Controller, secondary clocks, signaling devices and antennas must be installed by qualified persons in conformance with applicable national and local electrical codes. Improper installation of this equipment can result in lethal electrical shock and fire.

Disconnect and lock out electrical power to the unit before removing the wiring compartment cover.

Voltage applied to clock and signal relay contacts must not exceed 250vac.

The SiteSync IQ Master should be installed in a secure location protected from:

- Physical damage
- Water, including condensation
- Direct sunlight
- Operation by untrained personnel

Injury From Radio Frequency Transmissions: Do not operate the SiteSync IQ System Controller or External Transmitter when somebody is either touching the transmitting antenna or standing within 2-3 ft. (60-90 cm) of it, to avoid the possibility of radio frequency burns or related physical injury. Do not allow children to operate or play with or near the transmitting equipment.

Dynamite Blasting Caps: Operating the SiteSync IQ System Controller or External Transmitter within 500 ft. (150 m) of dynamite blasting caps may cause them to explode. Turn OFF these units when in an area where blasting is in progress.

FCC Warning: This equipment may generate or use radio frequency energy. Changes or modifications to this equipment may cause harmful interference unless the modifications are expressly approved in the instruction manual. The user could lose the authority to operate this equipment if an unauthorized change or modification is made.

The above warning list is not intended to include all hazards that may be encountered when using this equipment.

Introduction	
System Controller Standard Features and Specifications	4
System Controller Optional Features	5
Analog Clock Features	5
Digital Clock Features	5
Installation/Programming Instructions for System Controller	
System Controller, Antenna and External Transmitter Installation	6-9
System Controller Setup Wizard	10-13
Standard GPS Installation	14-15
GPS Plus Installation	16-17
Ethernet Installation	18-20
Adjust Time Menu	20
Wired Clock Circuit Installation	21
Wired Signal Circuit Installation	22-31
Contact Closure Sync Installation	32
Time Zone Clock Installation	33
Remote Connect Web Interface	34-43
Settings and Configurations:	
Manually Setting Time and Date	44
Manage Locks	45
Quiet Mode	45
Time Sync Priority	45
Clock Code	45
Clear/Restore	45
Setup Manager	46
Banner Text	46
Display Settings	46
Auto DST Settings	46
USB Flash Drive	46
Installation Instructions for Clocks	
Wireless Analog Clock Installation (AA Battery and AC)	47-48
Digital Clock Installation (Surface, Flush and Double-Face)	49-50
Troubleshooting	
System Controller	51
GPS	52
Ethernet	53
Remote Connect	54
Contact Closure Sync and Wireless Sync	55
Wired Clock Circuit	56
Wired Signal Circuit	57
Analog Clocks	58
Digital Clocks	59
Appendix A: Ethernet Timekeeping - Known Good Internet Time Servers	60
Appendix B: Supported Time Zones	61
Appendix C: Tone Generator Wiring	63
Appendix D: Wired Signal Circuit Programming Examples	63-65
Appendix E: Checking IQ System Controller Status Information	66
Appendix F: USB Flash Drive	67
Appendix G: Port Diagram	68
Appendix H: Maintenance Guide	69
Appendix I: Clock Circuit Wiring Diagrams	70-74
Appendix J: Clock Codes	75-77
Appendix K: Quiet Mode	78
Glossary	78-79

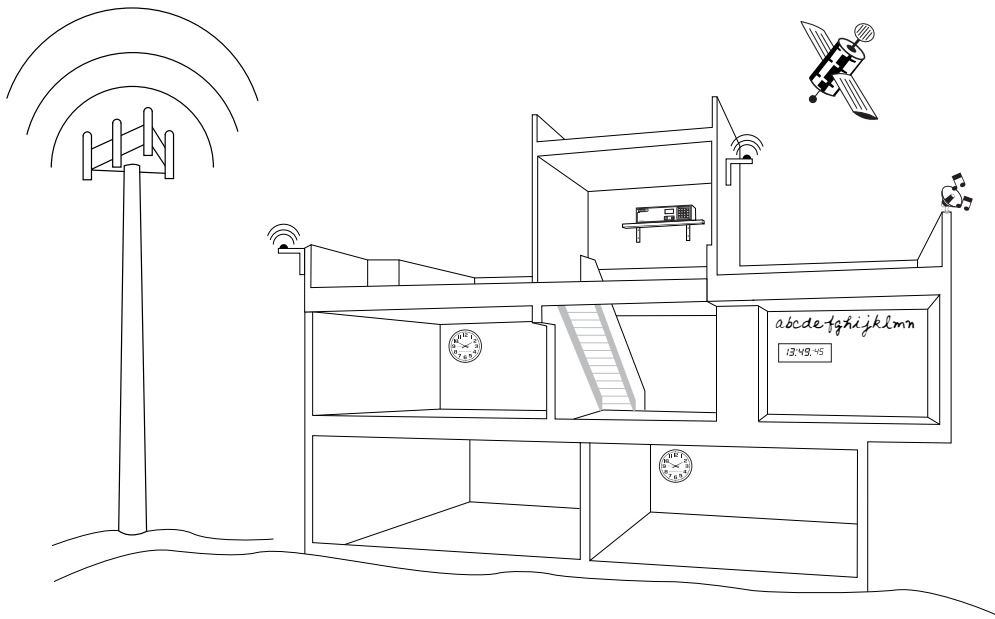

The American Time SiteSync IQ Wireless System offers the latest and most innovative way to incorporate synchronized time throughout your facility, providing you with improved productivity and punctuality.

SiteSync IQ System Controller Standard Features

The SiteSync IQ System Controller provides synchronized control of system clocks and electrical circuits such as those for controlling signaling devices and lights. Standard features include:

- Built-in keypad and LCD for setup and operation
- Internal clock accuracy of ± 1 minute per year (without synchronization)
- Two level password security
- Automatic Daylight Saving Time and Leap Year correction
- Programmable Custom and Automatic Daylight Saving Time
- Support for time zone clocks (up to eight unique time zones)
- Support for 5 and 10 watt internal transmitters plus connection to external transmitters of 30 watts

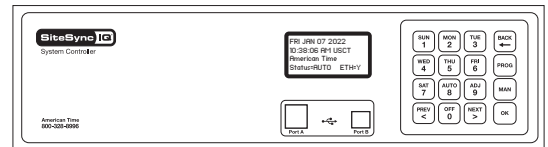

SiteSync IQ Wireless System Controller Specifications

Input Voltage to Power Adapter	100-240vac, 50/60 Hz
Output Voltage from Power Adapter	12.0 \pm 0.6 vdc
Peak Input Power	5 watt Internal TX - 45 watts 10 watt Internal TX - 65 watts
Average Power	5 watt Internal TX - 15 watts 10 watt Internal TX - 21.7 watts
Fuse (Input Power)	8 amps, 250vac, Subminiature
Standby Timekeeping	10 years
Memory/Time Backup	CR2032 lithium battery 240 mAh capacity
Timekeeping Accuracy	± 1 minute/year without correction from GPS or Ethernet time reference
Program Retention	Unlimited
Programmable Events	9,999 events total
Schedules	99 maximum
Signal Duration	Programmable 1-9 seconds or continuous On
Clock Circuits (2)	Dry contacts rated at 250vac, 8 amps resistive, 5 amps inductive
UL Listed	File #E157522

Clock Circuit Fuses (2)	8 amps, 250vac, subminiature
Signal Circuits (6)	Dry contacts rated at 240vac, Continuous: 7.5 amps resistive, 5 amps inductive, 50% duty
Cycle*	10 amps resistive
Physical Dimensions	5" h x 167/8" w x 8" d
Temperature Range	32° - 140°F (0° - 60°C)
Mounting	Desktop or rack mount (with optional rack mount ears)
Communication	Ethernet, RS-422 (GPS Plus), RS-232 (Std GPS), Contact Closure (2-wire) Sync
Shipping Weight	7 1/2 \pm 1/2 lbs.
Signal Circuits	0 or 6 (optional)
Display	128 x 64 graphics LCD
Keypad	16 button tactile feedback membrane switch
RF frequency range	450-470 MHz
Channel Spacing	12.5kHz
*50% duty cycle is defined as all signal relays on for one minute, off for one minute, repeating.	

SiteSync IQ System Controller Optional Features

- Automatic time synchronization with one or more external time references, including Ethernet and GPS
- Flexible control of 6 signal circuits, including manual operation
- Remote Connect web interface mode (Ethernet option) for event and circuit programming from a remote location

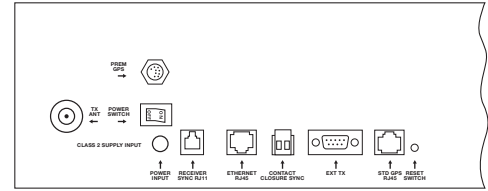

The following table shows the options included with each model number. The **W** in the model number indicates the power for the transmitter (00=none, 05=5 watt, 10=10 watt internal transmitters; 30=30 watt external transmitters). The **N** in the model number designates an internal transmitter (**Note:** change to a **C** for campus antenna with internal transmitter; **X** for external transmitter). The **S** in the model number indicates the number of clock and signal circuits (0 or 8) that can be controlled by that model.

Model No.	Standard GPS	GPS Plus	Ethernet	2-Wire Sync
SSQMSTR- W NSGE	X		X	
SSQMSTR- W NSPE		X	X	
SSQMSTR- W NSE			X	X

Examples: SSQMSTR-05N0E has 0 signal circuits on a 5 watt unit

SSQMSTR-10C8E has 1 clock circuit and 6 signal circuits on a 10 watt Ethernet unit with campus antenna

SSQMSTR-30X8GE has 1 clock circuit and 6 signal circuits on a 30 watt Standard GPS unit.

The American Time SiteSync IQ wireless clock series offers a selection of clocks to match a wide variety of application requirements. Plastic case, steel case, analog and digital styles will provide years of maintenance-free service.

SiteSync IQ Wireless Analog Clock Features

- Wireless time synchronization
- Built-in ultra-sensitive UHF receiver for facility wide signal reception
- Plug and play installation with no manual adjustments
- Battery clocks use six AA lithium batteries (included)
- Electric clocks - 120vac and 24vac (operate up to one hour during power interruption)
- Plastic case clocks are high-impact resistant with a shatter-resistant polycarbonate crystal
- Metal case clocks are durable steel, with powder-coat finish and convex glass crystal

SiteSync IQ Wireless Digital Clock Features

- Super-bright red LED for high readability
- Non-glare lens
- Selectable 12 or 24-hour format (except American series digital clocks, which use the time format display of system controller)
- ±1 second accuracy to master
- Black anodized aluminum frame (except American series digital clocks use steel enclosures)
- Visibility: 1.8 inches=75 ft.; 2.5 inches=150 ft.; 4 inches=250 ft.

System Controller with Internal Transmitter and Magnetic Mount Antenna

The Magnetic Mount antenna is standard equipment with 5 and 10 watt internal transmitter systems.

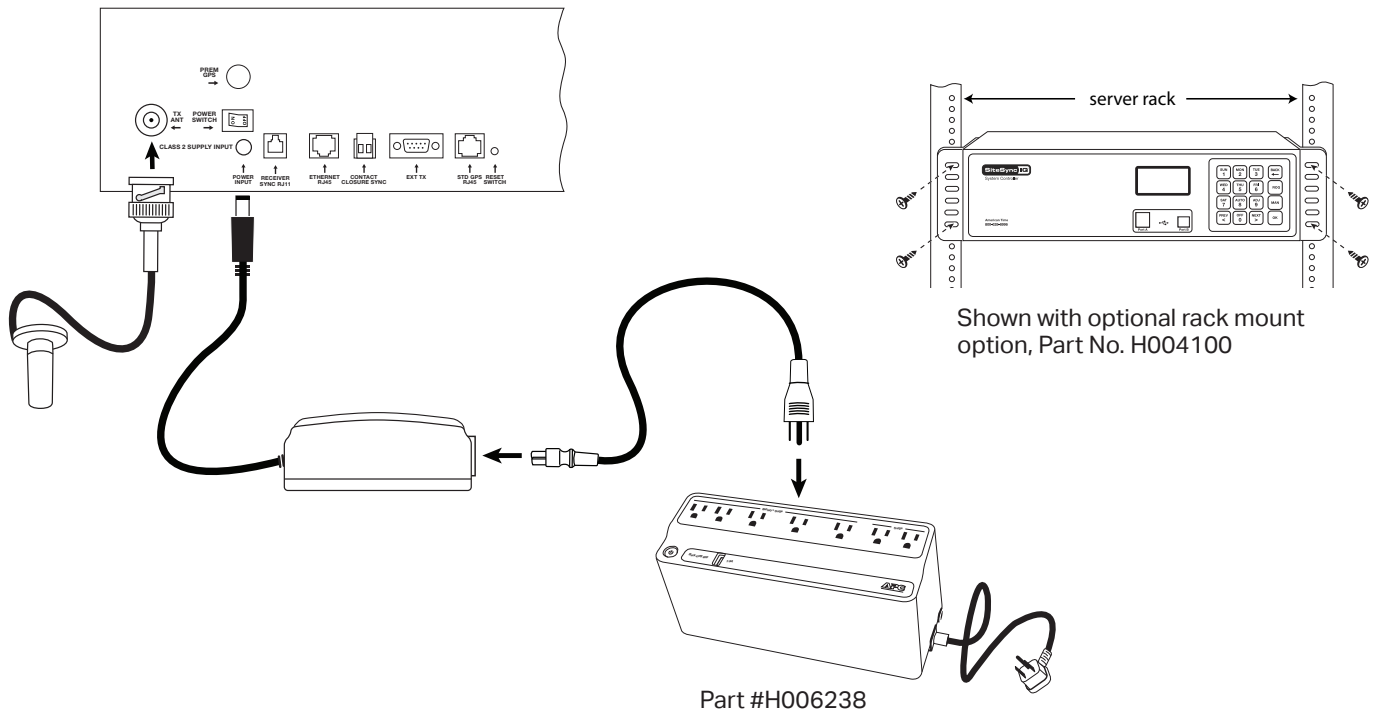

1. Choose a suitable location for the System Controller, following the safety precautions on Page 2.
 - a. Place the System Controller indoors.
 - b. Locate within 10 ft. of planned location for antenna.
 - c. Locate near an electrical outlet (120vac).
 - d. Rack or shelf mount.
 - e. If you have a sync option, review the applicable installation guidelines included in this manual.
2. Install the magnetic mount antenna per the instructions on Page 7.
3. Connect the cables to the System Controller:
 - a. Connect the antenna cable to the TX ANT port.
 - b. Connect the power supply to the POWER INPUT port.
 - c. Connect the power supply to 110v electrical supply (American Time recommends using surge protector/ battery backup Part # H006238 shown).
4. Turn on the power to the System Controller:
 - a. Place the rocker switch on the back of the unit to the ON position as shown above.
 - b. Confirm that the backlit display on the front of the unit lights up and displays text.
5. Follow the Setup Wizard instructions on pages 9-12.

■ **Note:** Follow these instructions for System Controllers ordered without a transmitter (for wired operation only), except disregard steps 1b and 3a.

Magnetic Mount Transmitting Antenna Installation

Component Location and Mounting Guidelines

1. Choose a suitable location for the SiteSync IQ magnetic mount antenna:
 - a. Locate the antenna at least 4 ft. away from the System Controller or other electronic equipment to minimize the potential for interference caused by the radio frequency energy emitted from the antenna.
 - b. Locate the antenna within approximately 10 ft. of the System Controller (the antenna includes 12 ft. of cable and should not be extended).
 - c. Place the antenna indoors or outside at a central location on the highest level of the facility (a rooftop penthouse usually works well, for example).
 - d. When installed outdoors, the location should be lower than other nearby building features or lightning rods to reduce the potential for lightning strikes.
 - e. Place the antenna in an area that is easily accessible for maintenance and inspection.
 - f. Avoid placing the antenna in an area where snow or ice may build up and possibly damage the antenna or cable.
 - g. Avoid placing the antenna in an area where people will touch it or come within 3 ft. of it during operation of the System Controller.
 - h. Avoid placing the antenna in an area surrounded by large metal objects that could block the radio signal and reduce signal coverage.
2. Mount the magnetic mount antenna vertically up or down (never horizontally):
 - a. On a metal object such as the underside of a ceiling beam or air duct. Be sure to test the pull strength of the magnetic base to make sure it is safely mounted.
 - b. On top of a mounting bracket, installed on the side of the building or other structure. You can use the same bracket supplied with the GPS option (American Time Part #H001233).

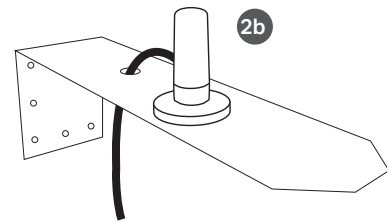
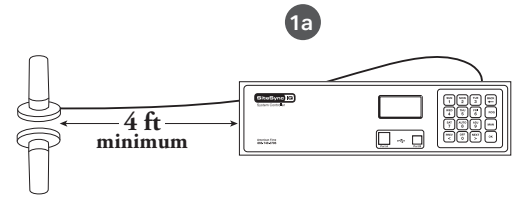

Shown mounted on bracket Part #H001233

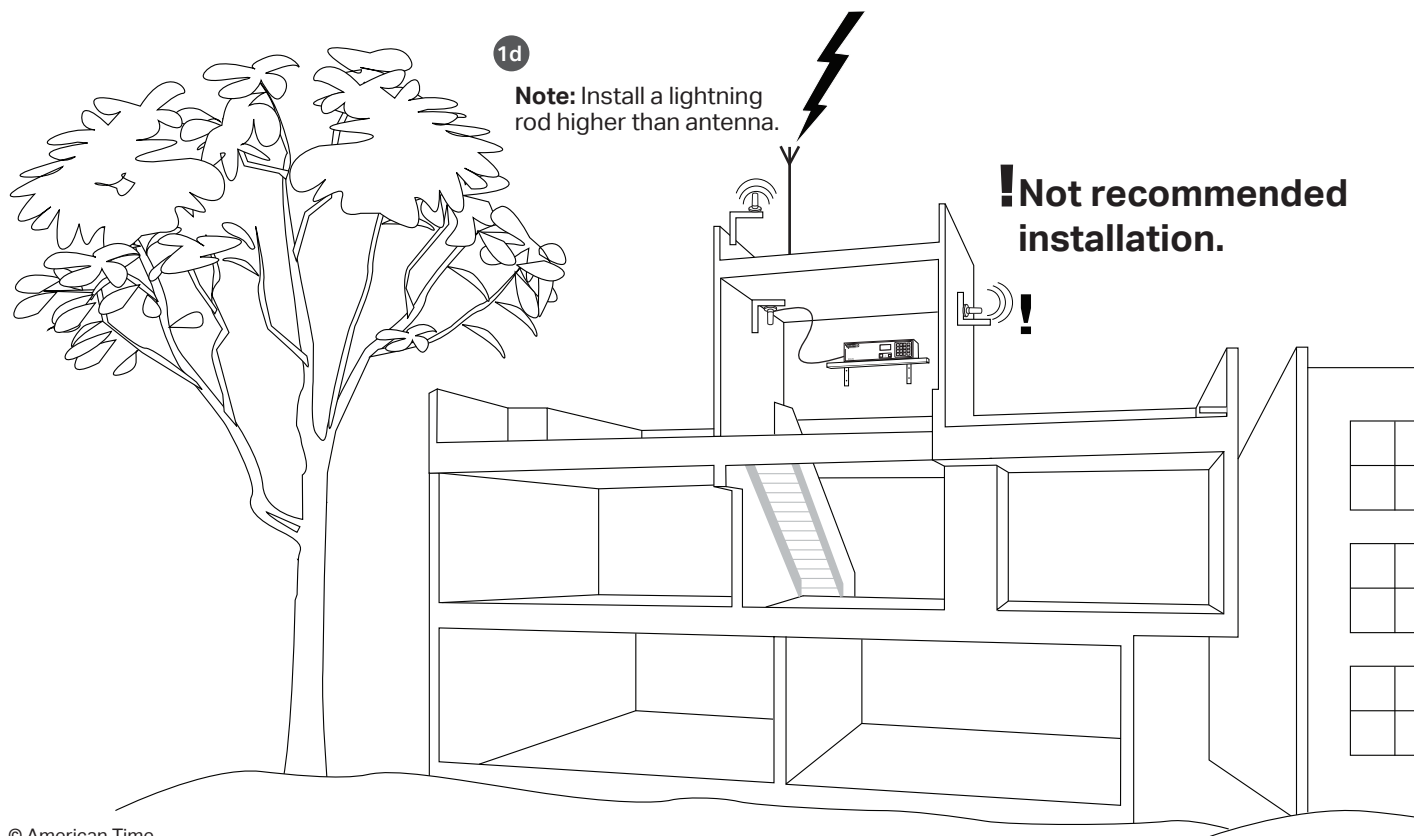

Campus Transmitting Antenna and External Transmitter Installation

System Controller with Internal Transmitter and Campus Antenna

The System Controller with 10 watt internal transmitter can also be connected to the campus antenna for improved coverage, especially where multiple buildings are being covered by a single transmitter.

1. Choose a suitable location for the System Controller, following the safety precautions on Page 1.
 - a. Place the System Controller indoors.
 - b. Locate within 45 ft. of planned location for antenna.
 - c. Locate near an electrical outlet (120vac).
 - d. Rack or shelf mount.
 - e. If you have a sync option, review the applicable installation guidelines.
2. Install the campus mount antenna per the instructions on Page 9.
3. Connect the cables to the System Controller:
 - a. Connect the antenna cable with adapter to the TX ANT port.
 - b. Connect the power supply to the POWER INPUT port.
 - c. Connect the power supply to 110v electrical supply (American Time recommends using surge protector/battery backup Part No. H006238 shown).
4. Turn on the power to the System Controller:
 - a. Place the rocker switch on the back of the unit to the ON position.
 - b. Confirm that the backlit display on the front of the unit lights up and displays text.

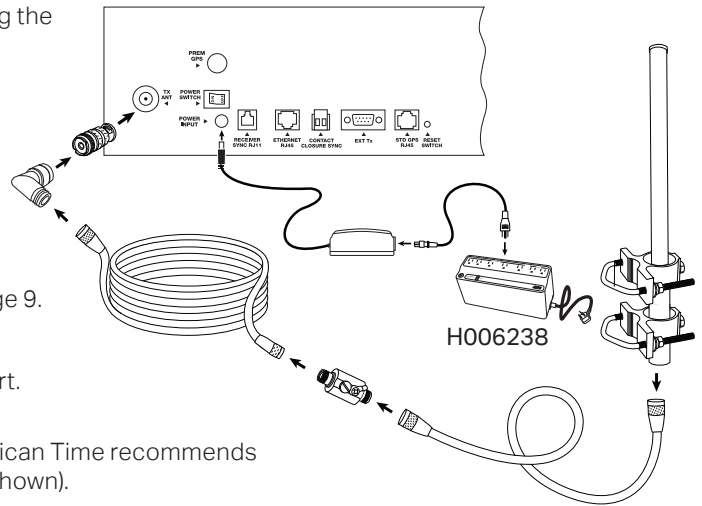

5. Follow the Setup Wizard instructions on pages 10-13.

System Controller, External Transmitter and Campus Antenna

Systems with 30 watt power external transmitters come standard with the campus antenna.

1. Choose a suitable location for the System Controller and the External Transmitter, following the safety precautions on Page 2.
 - a. Place the System Controller indoors.
 - b. Locate units within 4 ft. of each other and within 45 ft. of planned location for campus antenna.
 - c. Locate near an electrical outlet (120vac).
 - d. Rack or shelf mount.
 - e. If you have a sync option, review the applicable installation guidelines.
2. Install the campus mount antenna per the instructions on Page 9.
3. Connect the cables to the System Controller and External Transmitter:
 - a. Connect the 9-pin data cable between the EXT TX port on the System Controller and the DATA port on the external transmitter.
 - b. Connect the power cord to the External Transmitter.
 - c. Connect the power supply to the POWER INPUT port on System Controller.
 - d. Connect the power cords of both units 110v electrical supply (American Time recommends using surge protector/battery backup unit H006238 shown).
4. Power up the External Transmitter
 - a. Place the rocker switch on the back of the unit (under "Power Input" label) to the position marked "I".
5. Power up the System Controller:
 - a. Place the rocker switch on the back of the unit to the ON position.
 - b. Confirm that the backlit display on the front of the unit lights up and displays text.
6. Follow the Setup Wizard instructions on pages 10-13.

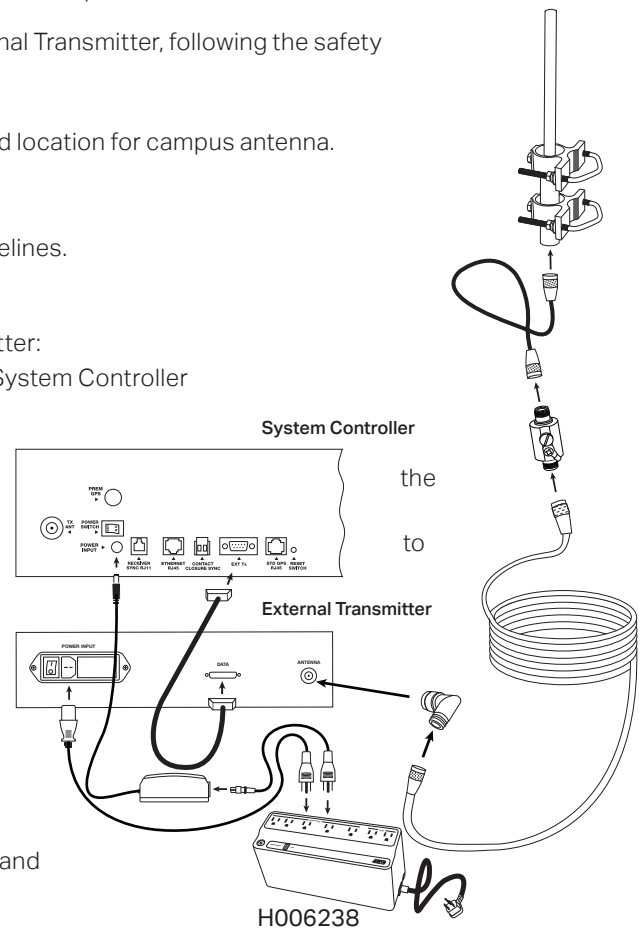

System Component Location and Mounting Guidelines

The Campus Antenna kit is recommended for outdoor antenna installations and improved signal coverage. It is standard equipment for all external transmitters and optional with 5 and 10 watt internal units.

The Campus Kit includes:

- A. Heavy-duty, outdoor type 20 inch fiberglass antenna
- B. 10 ft. RG-8/U COAX cable
- C. Lightning arrestor
- D. 50 ft. RG-8/U COAX cable
- E. N female to N male right angle adapter
- F. N female to BNC male adapter (only for direct connection to IQ System Controller)
- G. Mounting kit

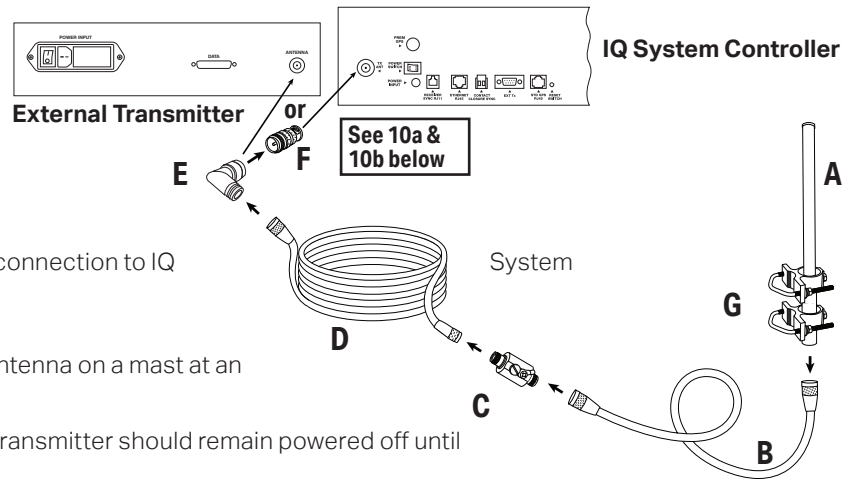

American Time recommends installing the Campus Antenna on a mast at an elevated location outdoors.

■ **WARNING:** The SiteSync IQ System Controller and transmitter should remain powered off until installation of the Campus Antenna is complete.

1. Select a suitable location for the SiteSync IQ System Controller, the external amplifier, if applicable, and Campus Antenna.
 - a. Locate the antenna at least 4 ft. away from the System Controller and external amplifier or other electronic equipment to minimize the potential for interference caused by the radio frequency energy emitted from the antenna.
 - b. Place the antenna indoors or outside at a central location on the highest level of the facility (a rooftop, for example).
 - c. Place the antenna in an area that is easily accessible for maintenance and inspection.
 - d. Avoid placing the antenna where people will touch it or come within 3 ft. of it during operation of the System Controller.
 - e. Avoid placing the antenna in an area surrounded by large metal objects that could block the radio signal and reduce signal coverage.
 - f. When installed outdoors, the location of the antenna should be lower than other nearby building features or lightning rods to reduce the potential for lightning strikes.
 - g. Identify a location in the proximity of a suitable means for grounding the lightning arrestor.
2. Install the Campus Antenna mast (not included) vertically. Mast should be circular and approximately 2 inches in diameter, and should be made of a non-rusting or rust-resistant rigid material.
3. Attach Campus Antenna (A) to 10 ft. cable (B) at mast end.
4. Attach mounting kit (G) to mast at Campus Antenna location.
5. Insert Campus Antenna into mounting kit and fasten set screws.
6. Route the 10 ft. cable (B) from mast to location of system controller or external transmitter. Secure cable with cable ties or other suitable method.
7. Connect lightning arrestor (C) to the 10 ft. cable (B) and to the ground rod (not included).
8. Connect the 50 ft. cable (D) to the lightning arrestor (C). If the lightning arrestor is outdoors, seal it and the attached COAX connectors to prevent moisture from entering.
9. Connect the N female to N male right angle adapter (E) to the 50 ft. cable (D).
10.
 - a. If you are connecting the Campus Antenna to a System Controller, use the BNC male connector (F). Connect the N female to N male right angle adapter (E) to the N female to BNC male adapter (F), and connect this adapter to the system controller.
 - b. If you are connecting the Campus Antenna to an External Transmitter, use the N female to N male right angle adapter (E). Connect the N female to N male right angle adapter (E) to the External Transmitter.
11. Ground the lightning arrestor (C) per the National Electrical Code and any applicable local codes. Seal the COAX connections around the arrestor to prevent moisture from entering.

■ **Note:** This lightning arrestor is not designed to withstand a direct lightning strike. However, it can survive lightning strikes in the general area. See Troubleshooting section for information if you suspect the system has been struck by lightning.

System Controller Setup Wizard

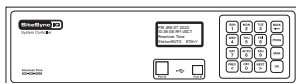

Programming Procedure

Turn on the power to the System Controller

The first time the unit is powered up, it will prompt you (See Setup Wizard Main Screen) to press:

SUN 1 To use the Setup Wizard

MON 2 Bypass the Setup Wizard temporarily

TUE 3 Disable the Setup Wizard

- **Note:** If you Bypass or Disable, the Setup Wizard will prompt you to **SUN 1** Enable or **MON 2** Disable transmissions.

1 Configure the System Controller

- Press **SUN 1** and enter 4-digit User Lock or enter 0000 to disable this feature.

- **Note:** User Lock is the security level used for accessing time/date and event menus.
 - Press **OK**

2 With the keypad, enter a 4-digit Service Lock, or enter 0000 to disable this feature.

- **Note:** Service Lock is the security level used for accessing System Controller configuration menus.
 - Press **OK**

3 Select local time zone by using the **PREV <** **NEXT >** keys or enter a time code from Appendix B.

- Press **OK** and skip to step (5). If a custom time zone is needed, press **ADJ 9** **ADJ 9** and **OK** and continue to step (4).

4 With the keypad, enter the numerical offset from UTC for Custom Time Zone.

- Use **PREV <** **NEXT >** to change + to -.
- Press **OK**

5 Select Daylight Saving Time (DST) option.

- Pressing **AUTO 8** causes automatic time changes to and from DST under the changeover dates currently in effect in the USA at the time of system manufacture. Press **OK** and skip to step (14).
- Pressing **ADJ 9** allows a custom DST to be entered. Press **OK** and continue to step (6).
- Pressing **OFF 0** turns off DST. Press **OK** and skip to step (14).

6 Define DST (For use when configuring custom DST settings)

- Press **SUN 1** to set fixed dates and times for the beginning and end of DST. Skip to step (7).
- Press **MON 2** to set months, weeks, weekdays and times (floating dates) for the beginning and end of DST. Skip to step (10).

Setup Wizard
1=Enter Now
2=Bypass
3=Disable

Setup Wizard
Transmissions
1=Enable
2=Disable

1

Config Menu
Choose User Lock:
XXXX
0000=Disable OK=Done

2

Config Menu
Choose Service Lock:
XXXX
0000=Disable OK=Done

3

Set Menu LOCAL
Time Zone Code: 05
99=Custom USCT
◁=Scroll OK=Accept

4

Set Menu Bias LOCAL
Enter Time Zone
offset from UTC
+ 11:30 OK=Accept

5

Set Menu DST - LOCAL
Set DST (Auto)
8=Auto 9=Custom
0=Off OK=Accept

6

Set Menu DST - LOCAL
Define DST By:
1= Fixed Dates
2=Floating Dates



System Controller Setup Wizard

Programming Procedure (cont)

7 Select fixed dates for DST (START):

- Use **PREV** **<** **NEXT** **>** to scroll start month and day. Press **OK** to move to the next field.
- Use **PREV** **<** **NEXT** **>** or keypad to enter the start time. Press **OK** to move to the next field.
- Use **PREV** **<** **NEXT** **>** to select AM/PM. Press **OK** to accept.

8 Select fixed dates for DST (END):

- Use **PREV** **<** **NEXT** **>** to scroll end month and day. Press **OK** to move to the next field.
- Use **PREV** **<** **NEXT** **>** or keypad to enter the end time. Press **OK** to move to the next field.
- Use **PREV** **<** **NEXT** **>** to select AM/PM. Press **OK** to accept.

9 Select fixed dates for DST (BIAS):

- Use keypad to enter bias.
- Use **PREV** **<** **NEXT** **>** to select "+" or "-". Press **OK** to accept.

10 Select floating dates for DST (START DATE)

- Use **PREV** **<** **NEXT** **>** to scroll week, day and month. Press **OK** to move to the next field.
- Use **PREV** **<** **NEXT** **>** on the bias selection to change + and -.
- Use keypad to enter bias. Press **OK** to accept.

11 Select floating dates for DST (START TIME):

- Use **PREV** **<** **NEXT** **>** or keypad to enter the start time.
- Press **OK** to accept.

12 Select floating dates for DST (END DATE)

- Use **PREV** **<** **NEXT** **>** to scroll week, day and month. Press **OK** to move to the next field. Press **OK** to accept.

13 Select floating dates for DST (END TIME)

- Use **PREV** **<** **NEXT** **>** to enter the start time. Press **OK** to move to the next field.
- Use **PREV** **<** **NEXT** **>** to select AM/PM. Press **OK** to accept.

14 To set the time display mode for the System Controller, select 12/24 Hr Mode.

- Press **SUN 1** for 12 hour mode-AM/PM (1:00 PM)
- Press **MON 2** for 24 hour mode-Military (13:00)

If the System Controller has {Ethernet + GPS} as sync options, skip to (15).

If the System Controller has the {Ethernet only} skip to (17).

If the System Controller has the {GPS only}, skip to (27).

If System Controller has no sync options, skip to (28).

7

```
Set Menu DST - LOCAL
DST Start: Mar 30
Start Time: 01:00 AM
⊕ = AM/PM OK=ACPT
```

8

```
Set Menu DST - LOCAL
DST End: SEP 15
End Time: 02:00 AM
⊕ = AM/PM OK=ACPT
```

9

```
Set Menu DST - LOCAL
DST Bias: +00:00
⊕ = +/- OK=ACPT
```

10

```
Set Menu DST - LOCAL
Start of DST:
2nd SUN of MAR
Bias +1:00 OK=ACPT
```

11

```
Set Menu DST - LOCAL
Start Time:
01:00 AM
⊕ = AM/PM OK=ACPT
```

12

```
Set Menu DST - LOCAL
End of DST:
First SUN of NOV
OK=ACPT
```

13

```
Set Menu DST - LOCAL
End Time:
01:00 AM
⊕ = AM/PM OK=ACPT
```

14

```
Set Menu 12/24 Mode
Choose Mode: 1
1=12 HR (AM/PM)
2=24 HR (Military)
```

System Controller Setup Wizard



Programming Procedure (cont)

15 To configure unit sync options

- Press **SUN 1** to continue on to (16).
- Press **MON 2** to skip sync option setup. Please ensure proper time & date unit.

15

```
Setup Wizard
Setup Sync Options
1=Yes
2=No
```

16 To set Time Sync Priority

- For system controllers with more than one sync option configured, choose the sync option priority.
If the System Controller has the {GPS only}, skip to (27).

16

```
Config Menu
Time Sync Priority
1=(GPS)
2=Ethernet
```

17 Use the keypad to Enable DHCP or Disable to select static IP entry.

- Press **SUN 1** for enable DHCP
- Press **MON 2** for disable DHCP
- Press **OK** to accept

If you chose enable, skip to (22).

If you chose disable continue to (18).

17

```
Comm Menu
DHCP
1=Enable
2=Disable   OK=Done
```

18 Use the keypad to enter the Unit IP Address. This is a static address assigned by your Network Administrator. Enter preceding zeros as necessary.

- Unit IP Address:
- Pres **OK**

18

```
Comm Menu
Unit IP Address
192.168.001.001
<=Bksp   OK=Done
```

19 Use the keypad to enter the Subnet Mask. This is the subnet mask of your network. Enter preceding zeros as necessary.

- Subnet Mask:
- Pres **OK**

19

```
Comm Menu
Unit Subnet Mask
255.255.255.000
<=Bksp   OK=Done
```

20 Use the keypad to enter the Gateway IP. This is the IP address of your network's Gateway device. Enter preceding zeros as necessary.

- Gateway IP:
- Pres **OK**

20

```
Comm Menu
Enter Gateway IP
192.168.010.099
<=Bksp   Ok=Done
```

21 Use the keypad to enter the DNS IP. This is the IP address of your network's DNS server. Enter preceding zeros as necessary.

- DNS IP:
- Pres **OK**

21

```
Comm Menu
Enter DNS IP
008.008.008.008
<=Bksp   OK=Done
```

22 Use the keypad to use Manual IP's or a DNS IP for the same server.

- Press **SUN 1** for Manual IP
- Press **MON 2** for DNS IP
- Press **OK** to accept

If you choose Manual IP, continue to (23).

If you choose DNS IP, skip to (25).

22

```
Comm Menu
Time Server Entry
1=Manual IP
2=(DNS IP)  Ok=Done
```



System Controller Setup Wizard

Programming Procedure (cont)

23 Use the keypad to enter the Time Server address. Enter preceding zeros as necessary.

- Time Server Address: _____ Press

OR Press to accept the default set at the factory from the list of known good Internet Time Servers in Appendix A.

24 Use the keypad to enter the Alternate Time Server address. Enter preceding zeros as necessary.

- Alternate Time Server Address: _____ Press

OR Press to accept the default set at the factory from the list of known good Internet Time Servers in Appendix A.

25 This shows the currently selected time server DNS address. Use Remote Connect to change this value (see page 41).

- Press

26 The unit will prompt you to enter the Port Number. This is remote web access and should be set to 0080.

- Port Number: **0080**
- Press to accept the default (80) set at the factory

27 To confirm proper set up, sync each option.

- Press to sync.
 - If successful "Sync Successful" will display.
 - If not successful, "Sync Failed" will display. Refer to Troubleshooting.
- Press to exit the Sync Now function.

28 "Setup Wizard Successfully Completed" will be displayed when setup is complete. You will no longer be prompted on power-up for setup information.

29 The System Controller should now show the correct time and date on its display screen. Your System Controller is now set up for proper operation.

- Verify the unit is transmitting. **TX** should display for about 3 seconds every 30 seconds (approximately the top and bottom of every minute).
- For systems with an external transmitter, verify the **DATA** and **PTT** lights turn on when **TX** is displayed as described above.

You can continue to the other sections of this manual for further information on other features. If you have any questions or problems that cannot be resolved by following the steps in the Troubleshooting Guide, please contact Technical Support at American Time 800-328-8996.

23

```
Comm Menu
Time Server Address
131.107.013.100
<=Bksp      OK=Done
```

24

```
Comm Menu
Alt Time Srur Addr
173.014.055.009
<=Bksp      Ok=Done
```

25

```
Time Server DNS
3.americantime.pool
.ntp.org
Ok=Next
```

26

```
Comm Menu
Enter Port Number
for web access: 80
OK=Done
```

27

```
Set Menu
Time Sync Option is
Available: Ethernet
8=Sync now OK=Set
```

27b

```
Set Menu
Ethernet Sync
Failed
```

28

```
Setup Wizard
Successfully Completed
```

29

```
MON MAR 13 2023
10:38:06 AM USCT
American Time
Circrts=Auto      TX
```



Mounting and Connecting Standard GPS Receiver

This option provides time synchronization via the Global Positioning System (GPS). 15 ft. GPS cable can be extended up to 100 ft. with extensions (optimal range from programmer of 60 ft.).

Standard GPS Option Includes:

- a. GPS Receiver with 15 ft. cable
- b. Mounting Bracket

1 For best results, mount the GPS antenna to an outside wall or to a mast on the roof with a clear view of the sky.

- a. The location should be unobstructed by trees, branches, power lines and other buildings, etc.
- b. Avoid installing the GPS antenna near high power transmitting antennas.
- c. To avoid lightning strikes, the location should not be the highest point and such that any lightning rods are well above the antenna.
- d. The GPS antenna is environmentally sealed, but in colder climates, mount the antenna high enough to avoid getting buried by snow or ice.
- e. While not ideal, skylights or windowsills are possible locations. Avoid installation behind Low-Emissivity (Low-E) glass as the GPS signal has difficulty penetrating such glass.

2 Install included mounting bracket

- a. Allows for mounting on the side of a building or other structure
- b. It is recommended not to mount where there is excessive roof overhang

3 Connect cables to System Programmer

- a. Connect GPS receiver cable to STD GPS RJ45 port.
- **Note:** The GPS unit can be extended up to 100 ft. with optional extension cables.

Optional Extension Cables:

- PN: H001840 - 25 ft.
- PN: H001841 - 50 ft.
- PN: H001842 - 75 ft.
- PN: H001846 - 100 ft.

■ **WARNING:** Avoid extending outdoors as connectors may corrode.

■ **Note:** This option automatically syncs once per hour at a time preset at the factory.

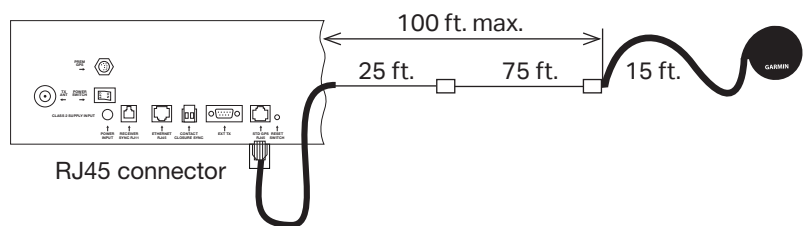
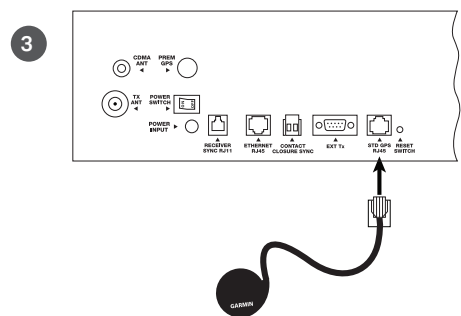
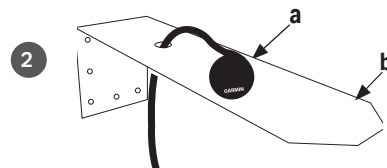
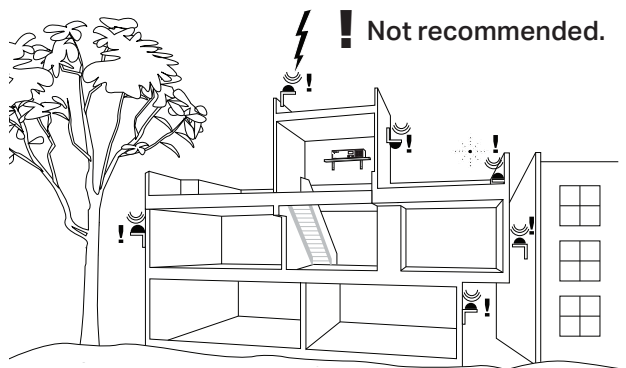
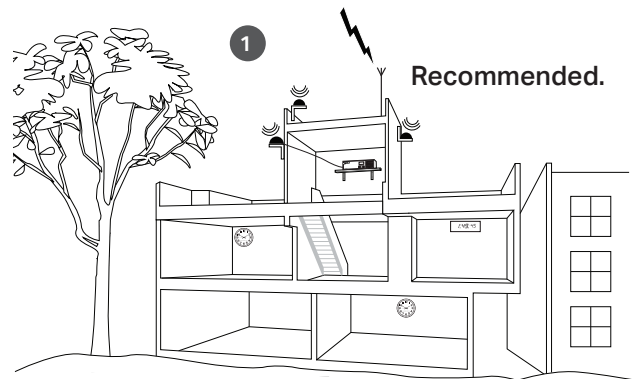



Programming Procedure

Turn on the power to the System Controller

1 To confirm GPS signal, press :

- Press to check signal status.
- If no signal was received, reference the troubleshooting guide.
- The Last Signal Received and the Last Attempted Reception may be displayed by pressing or .
- Press if signal was received to view number of connected satellites.

■ **Note:** If you see the number of satellites in view, press to return to the Main Screen.

If 0 satellites are connected, reference the troubleshooting guide.

■ **Note:** Allow GPS to synchronize. The time may be incorrect while the GPS is receiving its signals. This may take up to 25 minutes. After synchronization, the time and the satellites connected will be updated.

2 To sync System Controller with correct time & date:

- Press , to Set Menu Mode.
- Enter User Lock and press .
- Press , to sync the System Controller with GPS. Press until GPS option is chosen.
- Press to sync with GPS.

■ **Note:** If "GPS Sync Successful" is displayed, press to return to Main Screen.

If "GPS Sync Failed" is displayed, reference the troubleshooting guide.

The GPS sync option is now configured and will update the time on the System Controller automatically once each hour at a time preset at the factory.

■ **Note:** When GPS synchronization is working, GPS=S will be displayed on the screen in small text mode as shown in screen shot (3). If a synchronization attempt fails, GPS=N will be displayed.

1a

GPS Time Menu
Choose:
1=Signal Status
2=Enable/Disable

1b

GPS Time Menu
Signal Not Received
01-08-2023 12:28:15A
1=Last Good OK=Done

1c

GPS Time Menu LAST
Signal Last Received
01-08-2023 12:28:15A
>=Last Try OK=Next

1c

GPS Time Menu LAST
Attempted Reception
01-08-2023 12:28:15A
<=Last Good OK=Next

1d

GPS Time Menu NOW
Satellites: 3
01-10-2023 1:04:59A
USCST OK=Next

2b

Set Menu Mode
Enter User Lock:
XXXX
PROG=EXIT OK=ENTER

2c

Set Menu Mode
Time Sync Option is
Available: GPS
8=Sync now OK=Set

2d

3

MON MAR 06 2023
10:30:06 AM USCT
American Time
Circts=Auto GPS=S

Mounting and Connecting GPS Plus Receiver

This option provides time synchronization via the Global Positioning System (GPS). The option includes weather-tight, non-corrosive connections for outdoor installation and can be extended further (up to 1500 ft.) than the Standard GPS option.

Standard GPS Plus Option Includes:

- a. Premium GPS Receiver
- b. Antenna Mounting Kit
- c. 50 ft Cable
- d. Shrink Tubing

1 For best results, mount the GPS antenna to an outside wall or to a mast on the roof with a clear view of the sky.

- a. The location should be unobstructed by trees, branches, power lines and other buildings, etc.
- b. Avoid installing the GPS antenna near high power transmitting antennas.
- c. To avoid lightning strikes, the location should not be the highest point and such that any lightning rods are well above the antenna.
- d. The GPS antenna is environmentally sealed, but in colder climates, mount the antenna high enough to avoid getting buried by snow or ice.
- e. While not ideal, skylights or windowsills are possible locations. Avoid installation behind Low-Emissivity (Low-E) glass as the GPS signal has difficulty penetrating such glass.

2 Antenna Installation

- a. Installation on included mounting bracket
 - Allows for mounting on the side of a building or other structure.
 - It is recommended not to mount where there is excessive roof overhang.
- b. Installation if using a mast

■ Note: If using a mast, it must be grounded.

1. If using a mast, it should be made from 1" schedule 40 pipe, or any rigid tubing or conduit with an outside diameter of 1.5" or less.
2. Use the U-bolt, hex nuts and lock washers supplied to fix the mounting bracket to the mast.

3 Connect cables to System Programmer

- a. Connect GPS receiver cable to PREM GPS RS-422 port.
- **Note:** 50 ft. extension cables, PN: H000818, can be added between the cable provided and the System Controller. The cable provided with the kit should always be installed to the GPS antenna pigtail. The total length of all cables should not exceed 1500 ft., (up to 30 standard extension cables).

- **Note:** This option automatically syncs once per hour at a time preset at the factory.

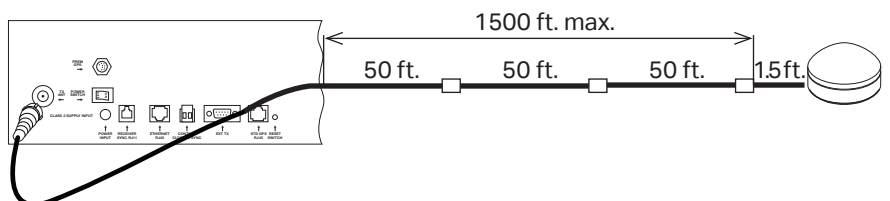
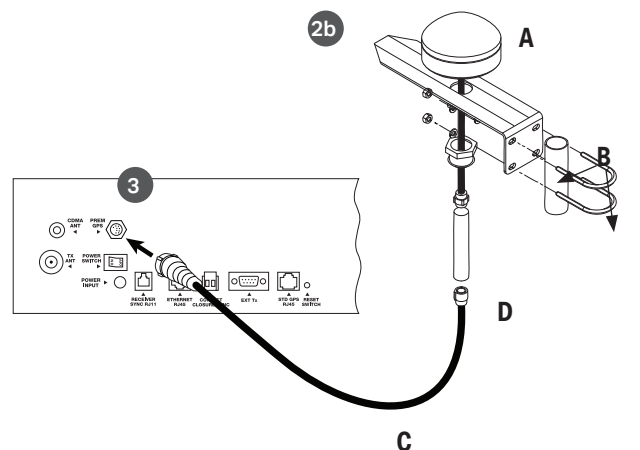
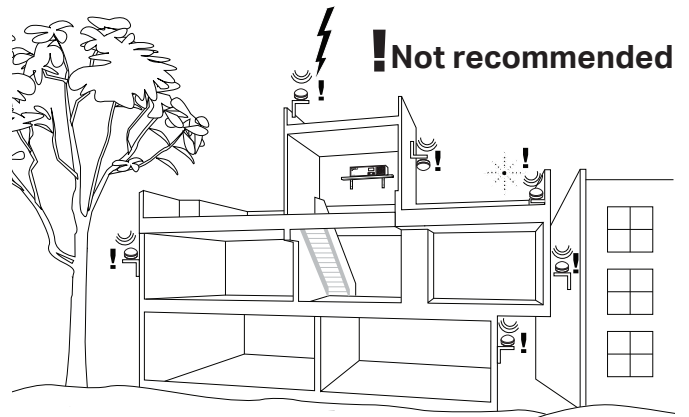
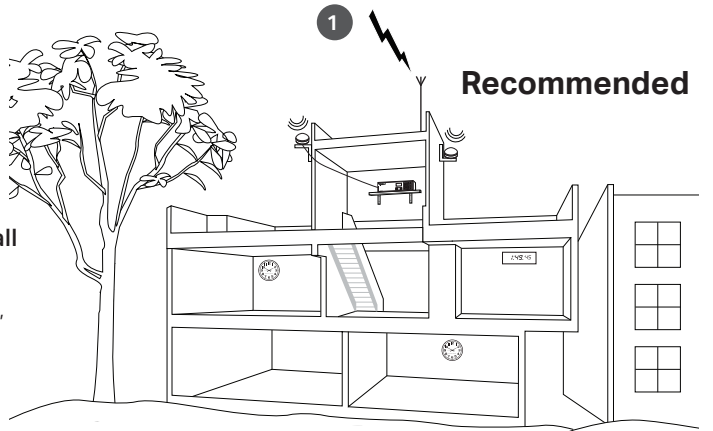

Programming Procedure

Turn on the power to the System Controller

- 1 To confirm GPS signal, press **PROG** **SUN 1**:
 - a. Press **SUN 1** to check signal status.
 - b. If no signal was received, reference the troubleshooting guide.
 - c. The Last Signal Received and the Last Attempted Reception may be displayed by pressing **PREV <** or **NEXT >**.
 - d. Press **OK** if signal was received to view number of connected satellites.
 - **Note:** If you see the number of satellites in view, press **OK** **BACK** **BACK** to return to the Main Screen.

If 0 satellites are connected, reference the troubleshooting guide.

- **Note:** Allow GPS to synchronize. The time may be incorrect while the GPS is receiving its signals. This may take up to 25 minutes. After synchronization, the time and the satellites connected will be updated.

- 2 To sync System Controller with correct time & date:
 - a. Press **PROG** **SUN 1** to Set Menu Mode.
 - b. Enter User Lock and press **OK**.
 - c. Press **ADJ 9** to sync the System Controller with GPS. Press **NEXT >** until GPS option is chosen.
 - d. Press **AUTO 8** to sync with GPS.
 - **Note:** If "GPS Sync Successful" is displayed, press **OK** **BACK** **BACK** to return to Main Screen.

If "GPS Sync Failed" is displayed, reference the troubleshooting guide.

The GPS sync option is now configured and will update the time on the System Controller automatically once each hour at a time preset at the factory.

- **Note:** When GPS synchronization is working, GPS=S will be displayed on the screen in small text mode as shown in screen shot (3). If a synchronization attempt fails, GPS=N will be displayed.

1a

```
GPS Time Menu
Choose:
1=Signal Status
2=Enable/Disable
```

1b

```
GPS Time Menu
Signal Not Received
01-08-2023 12:28:15A
1=Last Good OK=Done
```

1c

```
GPS Time Menu LAST
Signal Last Received
01-08-2023 12:28:15A
>=Last Try OK=Next
```

1c

```
GPS Time Menu LAST
Attempted Reception
01-08-2023 12:28:15A
<=Last Good OK=Next
```

1d

```
GPS Time Menu NOW
Satellites: 3
01-10-2023 1:04:59A
USCST OK=Next
```

2b

```
Set Menu Mode
Enter User Lock:
XXXX
PROG=EXIT OK=ENTER
```

2c

2d

```
Set Menu Mode
Time Sync Option is
Available: GPS
8=Sync now OK=Set
```

3

```
MON MAR 06 2023
10:30:06 AM USCT
American Time
Circets=Auto GPS=S
```



Connecting Ethernet Option

This option provides time synchronization via Simple Network Time Protocol (SNTP) or Daytime Protocol from Internet Time Servers or an internal Network Time Server.

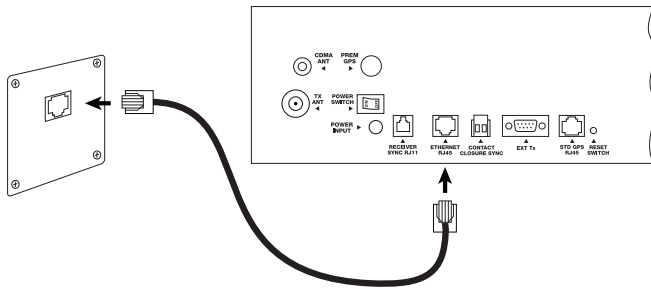

Ethernet Option requires:

1. TCP/IP Network with Internet access or connection to a Network Time Server.
2. Cat 5 or above patch cable (not included).
3. Hostname:

- **Note:** *Record the last 6 digits of device Serial number (located on back of system controller) after the asterisk (*). The Hostname can be used to identify the system controller on the network for DHCP.
- **Note:** The default ethernet settgin has DHCP enabled to automatically obtain an IP address from a DHCP server. If no DHCP address is received, the device will default to 192.168.10.10.

4. *Unit IP Address from Network Administrator:
5. *Subnet Mask:
6. *Gateway IP Address:
7. *DNS Server IP Address:

*Not required if DHCP is Enabled

8. Port Number (defaulted to 80):
9. Time Server DNS Address:
10. Time Server IP Address:
11. Alternate Time Server Address:

See Appendix A for a list of Internet Time Server addresses (or use the address of a server on your local network).

- **Important Note:** Time Servers provide time sync for UTC Time, but do not set Time Zone or DST settings.
- **Note:** This option automatically syncs once per hour at a time preset at the factory.

Configuration 1: Receive Time Sync via the Internet (SNTP or Daytime Protocol)

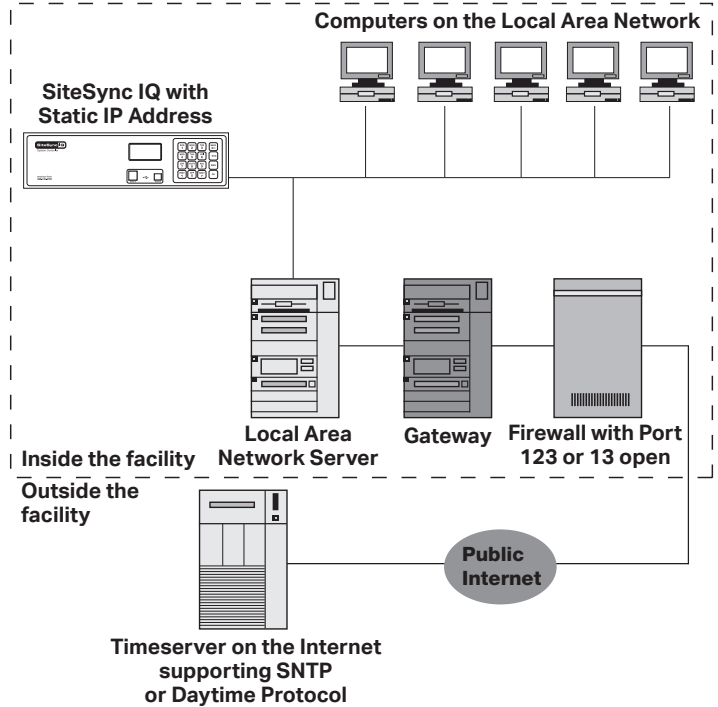

Configuration 2: Receive Time Sync via the Internal Network (SNTP)

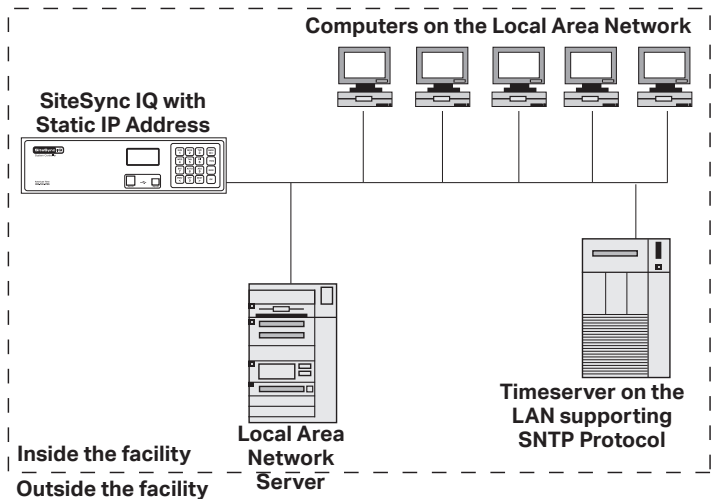



Programming Procedure - Keypad

- **Note:** These settings may already have been entered using the Startup Wizard.

Turn on the power to the System Controller

1 Configure Communication (Comm) Settings:

Press **PROG** **SAT 7** **TUE 3** to access Comm Settings:

- Use the keypad to Enable DHCP or Disable to select static IP.
 - Press **SUN 1** to enable DHCP. **Skip to f.**
 - Press **MON 2** to disable DHCP
 - Press **OK** to accept
- Use the keypad to enter the Unit IP Address. This is a static address assigned by your Network Administrator. Enter preceding zeros as necessary. Press **OK**
- Use the keypad to enter the Subnet Mask. Enter preceding zeros as necessary. This is the subnet mask of your network. Press **OK**
- Use the keypad to enter the Gateway IP. Enter preceding zeros as necessary. This is the IP address of your network's Gateway device. Press **OK**
- Use the keypad to enter the DNS IP. Enter preceding zeros as necessary. This is the IP address of your network's DNS server. Press **OK**
- Use the keypad to use Manual IP's or a DNS IP for the time server.
 - Press **SUN 1** for Manual IP
 - Press **MON 2** for DNS IP. **Skip to i.**
 - Press **OK** to accept
- Use the keypad to enter the Time Server Address. Enter preceding zeros as necessary. Press **OK**.

OR Press **OK** to accept the default set at the factory from the list of known good Internet Time Servers in Appendix A.

- Use the keypad to enter the Alternate Time Server Address. Enter preceding zeros as necessary. Press **OK**. **Skip to j.**

OR Press **OK** to accept the default set at the factory from the list of known good Internet Time Servers in Appendix A.

- This shows the currently selected Time Server DNS address. Use Remote Connect to change this value (see page 35). Press **OK**.
- The unit will prompt you to enter the Port Number. This is for Remote Connect web access and should be set to **0080**.

Press **OK** to accept the default (80) set at the factory.

- Press: **OK** **BACK** **BACK** to return to Main Screen.

Programming Procedure continued on following page.

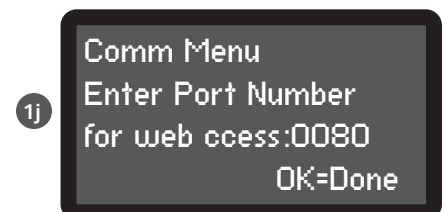
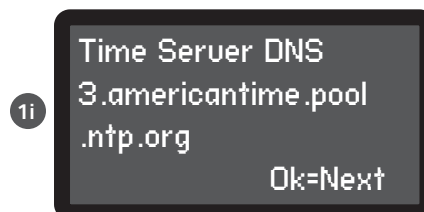
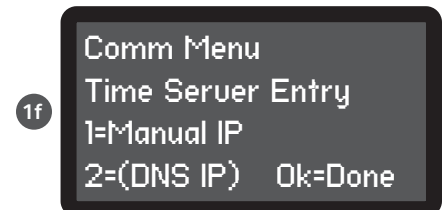
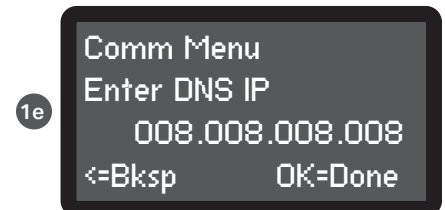
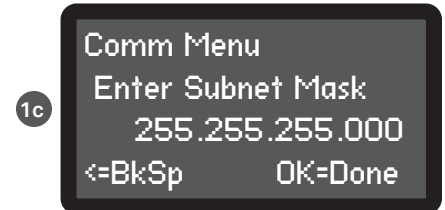
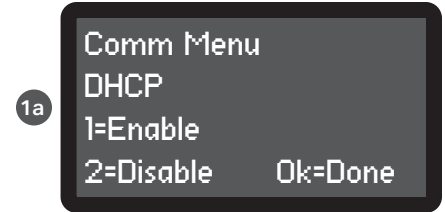



Programming Procedure - Keypad (continued)

2 Sync System Controller with correct time & date:

- a. Press: **PROG** **SUN 1** to Set Menu Mode.
 - a. Enter User Lock and press **OK**.
 - b. Press **ADJ 9** to sync the System Controller with Ethernet. Press **NEXT >** until Ethernet option is chosen.
 - c. Press **AUTO 8** to sync with Ethernet.
- **Note:** If "Ethernet Sync Successful" is displayed, press: **OK** **BACK** **BACK** to return to Main Screen.

If "Ethernet Sync Failed" is displayed, reference the troubleshooting guide.

3 The Ethernet sync option is now configured and will update the time on the System Controller automatically once each hour at a time preset at the factory.

- **Note:** When Ethernet synchronization is working, ETH=S will be displayed on the screen in small text mode as shown in screen shot 3. If a synchronization attempt fails, ETH=N will be displayed.

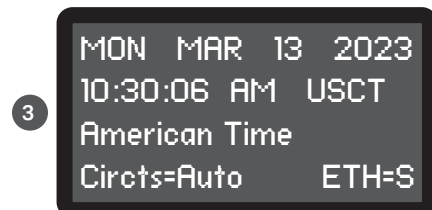
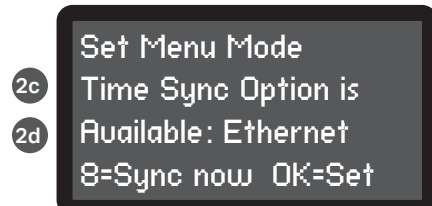
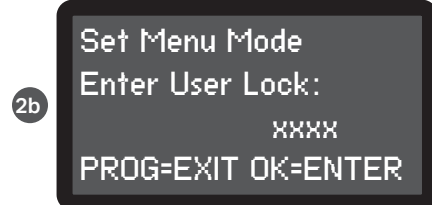

Adjust Time Menu

The Adjust Time menu serves two functions:

1. Manual correction of impulse secondary clocks, and
2. Simple synchronization of the system controller to an external time source.

Programming Procedure

1 Press **ADJ 9** to access the Adjust Time Menu

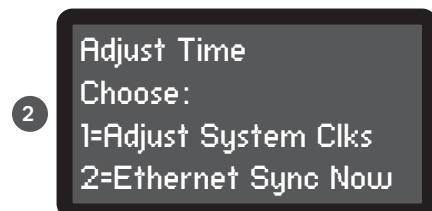

2 Press **SUN 1** to enter Adjust System Clocks Menu

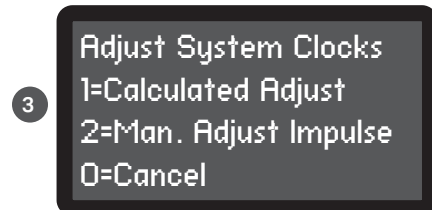

3 Press **SUN 1** to bring up the Calculated Adjust screen

- a. Enter the time shown on the secondary clocks (to the nearest minute). The time entered should be in 12 hour format as AM/PM settings are irrelevant.
- b. Press **OK**. The time difference between the secondary clocks and the system controller is displayed.
- c. Press **OK** to initiate automatic correction of the secondary clocks and return to the Adjust Time screen.

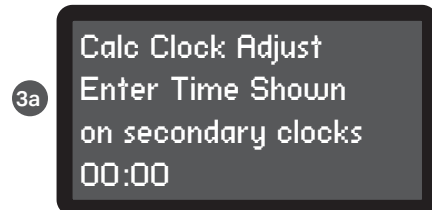

4 Pressing **MON 2** in the Adjust System Clocks menu (#3 at right) brings up the Manual Adjust screen.

- a. Press **NEXT >** repeatedly to correct impulse clocks manually.
- b. Press **OK** when finished to return to the Adjust Time menu.

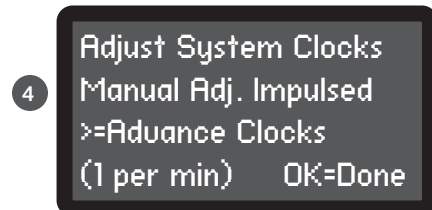

5 Pressing **MON 2** in the Adjust Time screen (#2 above) causes the unit to attempt synchronization with external time sources* in order of priority. If successful, a message confirming this flashes before the Time Display screen appears.

*The time sync priority can be configured. Reference Settings and Configuration, pg 45.



Wired Clock Circuit Installation

To install wired clock circuits:

1. Disconnect and lock out power to the SiteSync IQ System Controller and any circuit wiring.
2. Remove the top cover from the System Controller.
 - a. Remove screws from each side of the cover.
 - b. Slide the cover up off the base of the unit.
3. Route signal circuit wires into the wiring compartment of the System Controller.
 - a. Remove knockout(s). See Appendix G for illustration showing knockout locations on the rear side of the unit.
 - b. Use copper conductors only.
 - c. Use strain relief connector fittings in the knockout holes to secure the wires.
 - d. Route the wires into the wiring compartment, leaving enough slack to make all connections to the relay terminals.
4. Connect clock wires to the circuit relay terminals

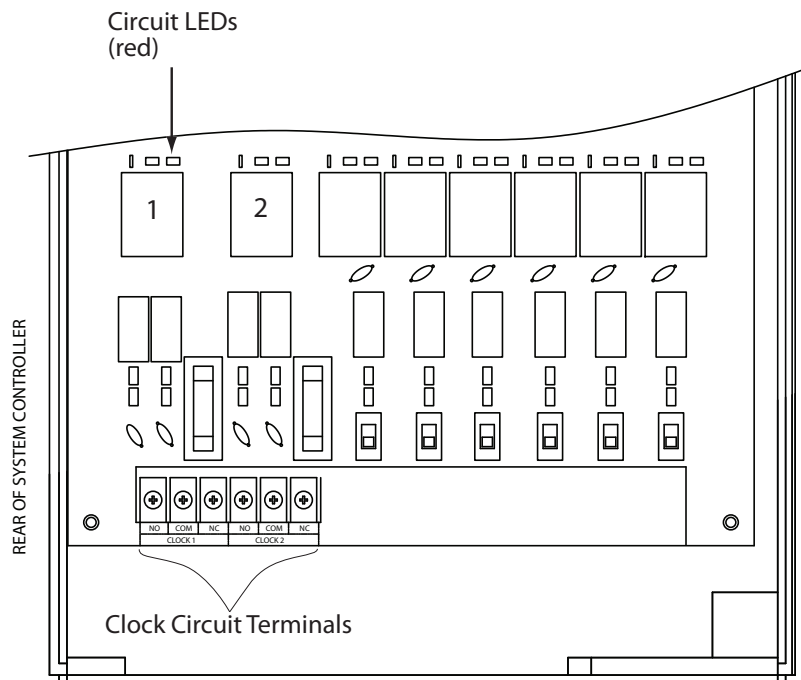

See Appendix I for Clock Circuit Wiring Diagrams

Wired Signal Circuit Option



Wired Signal Circuit Installation

To install wired signal circuits (for electrical device control including bells, tone generators, lights, etc.):

1. Disconnect and lock out power to the SiteSync IQ System Controller and any circuit wiring.
 2. Remove the top cover from the System Controller.
 - a. Remove screws from each side of the cover.
 - b. Slide the cover up off the base of the unit.
 3. Route signal circuit wires into the wiring compartment of the System Controller.
 - a. Remove knockout(s). See Appendix G for illustration showing knockout locations on the rear side of the unit.
 - b. Use copper conductors only.
 - c. Use strain relief connector fittings in the knockout holes to secure the wires.
 - d. Route the wires into the wiring compartment, leaving enough slack to make all connections to the relay terminals.
 4. Connect signal wires to the circuit relay terminals.
 - a. Route the power (feed) line of each circuit to the COM terminal of the desired circuit (1-6) being connected.
 - b. Route the switched (load) line of each circuit to the NO terminal of the desired circuit (1-6) being connected.
 - c. Label the wires for each circuit as desired.
- **Note:** The signal circuits are protected with surge suppression components. In some applications, this protection can cause leakage current to trigger the output device(s) when the circuit is switched ON. In these cases, the surge protection switches (see illustration below) can be moved to the OFF position.
Contact American Time Technical Support with any questions at **800-328-8996**.

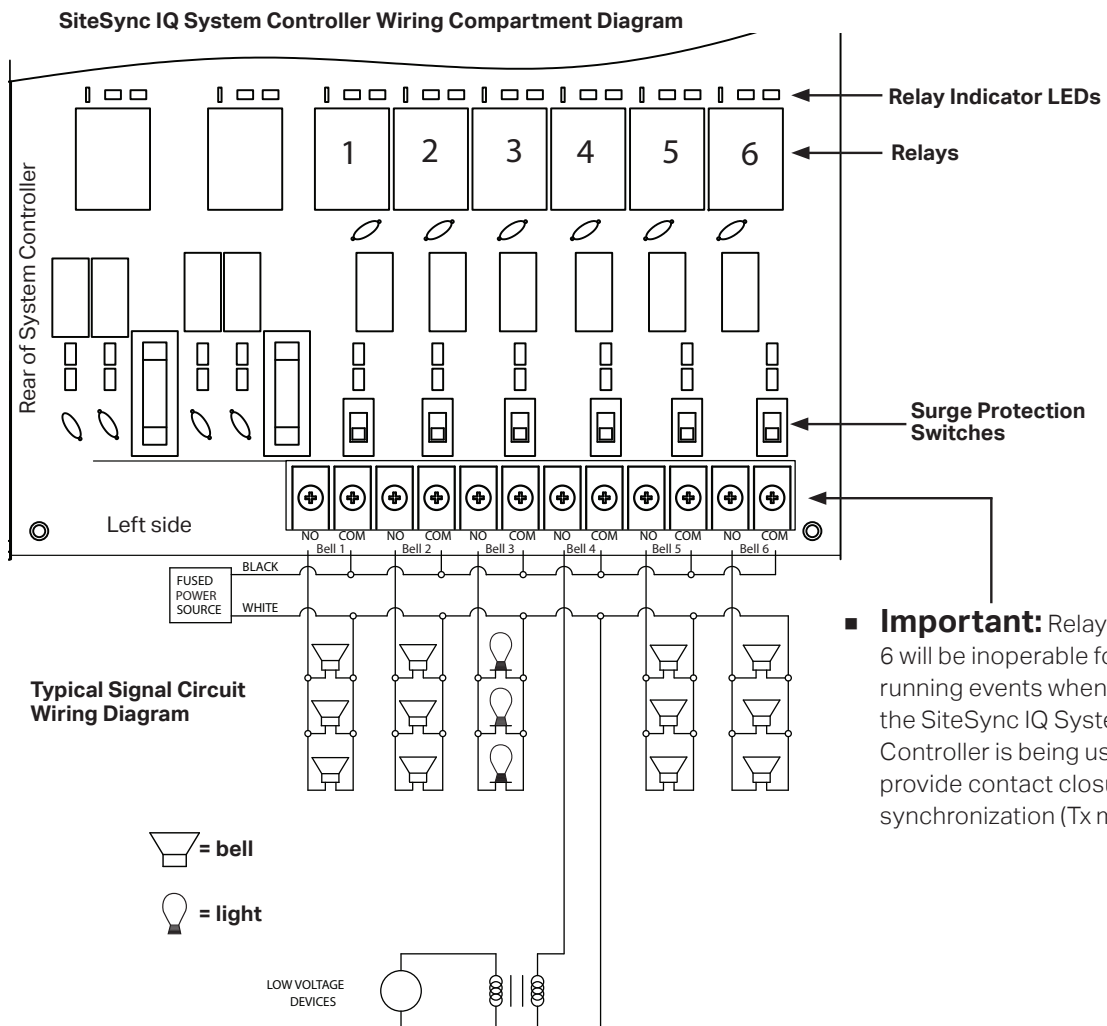



Programming Events (Keypad Interface)

The SiteSync IQ System Controller contains 6 integrated signal relays. When configured, the Wired Signal Circuit Option allows the System Controller to be used for operating bells, tone generators, lighting circuits and other electrical equipment. Events may also be configured to trigger countdown digital clocks that are equipped with the Countdown adder (SQDxxxxxC[1-6]).

- **Note:** System Controllers with the Ethernet option can also be programmed via the Remote Connect web interface (see page 37).

Definitions:

An **Event** is programmed into the System Controller with time and date information, as well as a duration or a start/stop command. For example, Event 0001 may be programmed to execute every Monday, Wednesday and Friday at 10:00 am for 3 seconds.

Each event is assigned to a **Schedule**. The SiteSync IQ System Controller can store up to 9,999 events. The event duration is programmable from 1 to 9 seconds and also allows for ON or OFF commands. Normal events are recurring weekday events. A **Special Event** contains date information that is not specific to weekdays. For example, you can set a special event for the 4th day of every month, the 4th day of every January or the 4th day of January in a specific year. You can also set a special event for every Thursday in January or every Thursday in a specific year. A **Schedule Change Event** is entered in the same manner as a **Special Event**. A schedule change event allows you to change from one schedule to another. This may be useful for changing from a normal schedule to a holiday schedule.

A **Schedule** is a group of events. For example, a school might program Schedule 01 with 4 events for their morning Elementary recess schedule. The SiteSync IQ System Controller allows for 99 unique schedules, with any number of events in each (up to a maximum total of 9,999 events). Schedules, with groups of events, are assigned to **Circuits**.

A **Circuit** is defined as one of the 6 relay outputs on the SiteSync IQ System Controller. Each circuit can be assigned one schedule at a time. For example, Schedule 01 with 4 events might be assigned to Circuit 1 and Schedule 03 with 10 events might be assigned to Circuit 2.

A **Circuit** is defined as one of the 6 relay outputs on the SiteSync IQ System Controller. Each circuit can be assigned one schedule at a time. For example, Schedule 01 with 4 events might be assigned to Circuit 1 and Schedule 03 with 10 events might be assigned to Circuit 2.

1 Programming New Events

- Press: **PROG** **MON 2**. Enter User Lock using the keypad and press **OK** to enter the Event Menu.
 - Press **SUN 1** to add an event.
 - Select the number of the schedule for the new event and press **OK**.
 - If any events have already been assigned to the selected schedule, the days and start time for the first event are displayed. Use the **NEXT >** key to move to the New Event screen. Press **OK** to display the Select Weekdays screen.
- **Note:** Press **PREV <** on the first event to view the last event. Press **NEXT >** to move to the New Event Screen.
 - e. To program event days, press **SUN 1** through **SAT 7** keys to add or remove days individually, or
 - Press **AUTO 8** to add weekdays (shown), **ADJ 9** to add weekends, or
 - Press **OFF 0** for special events or schedule change events. This allows events to be defined by date(s). Please reference Sections 3 (Programming Special Events) and 4 (Programming Schedule Change Events) for details.
 - f. Press **OK** to accept the assigned days.

2 Programming Recurring Events by Weekday

For a non-special event, this brings up the Event Time screen. To program start time:

- Use the number keys to enter the hour and minute. Press **PREV <** for AM or **NEXT >** for PM. Press **OK** to accept the event start time.

The Event Duration screen appears. To program event duration (1-9 seconds):

- Press any number 1-9 to specify duration, or:
 - Press **OFF 0** to use the default duration(s) for the circuit(s) assigned to the schedule, or
 - Press **NEXT >** to latch assigned circuits on until a later event turns them off, or
 - Press **PREV <** to turn off assigned circuits that were previously turned on.
 - Press **OK** to accept event duration.

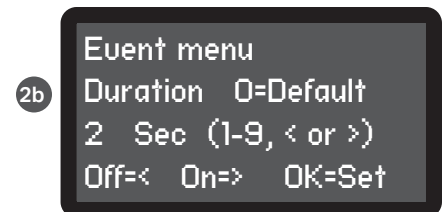
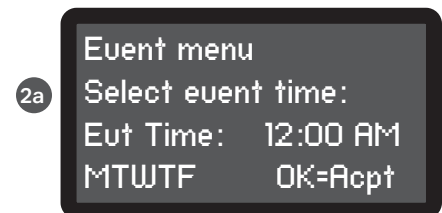
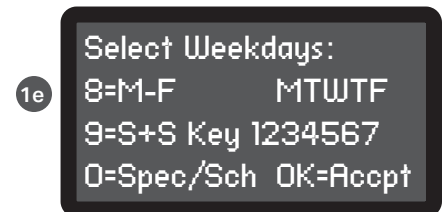
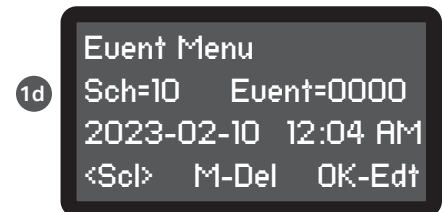
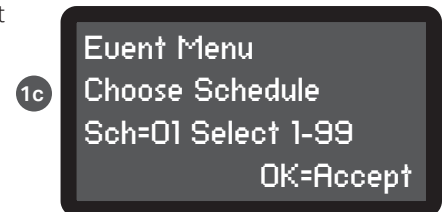
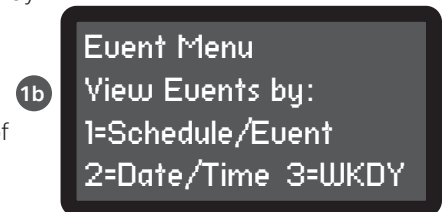



Programming Recurring Events by Weekday (continued)

The Countdown Duration screen appears:

- c. Enter the countdown duration using the keypad or the **PREV** **NEXT** scroll keys. Press **OK**.

- **Note:** This countdown duration is only applicable if you have an SQDxxxxxxC(1-6) digital clock. A countdown duration of 0 disables this feature.

The Message Number screen appears:

- d. Enter the message number (see below) using the keypad. Press **OK**.

- **Note:** This message number is only applicable if you have an SQDxxxxxxC(1-6) digital clock. A message number of 0 disables this feature.

The Choose Schedule screen reappears:

- e. Press **OK** to accept the schedule number.
- f. The Event Saved screen briefly appears followed by the Select Event Time screen.
- g. If a new event is to be programmed with the same assigned schedule, days and duration as the previous event, Press **SUN 1**. Enter only the start time of the new event and press **OK**. Follow this procedure for all new events sharing the same schedule, days and duration.

To see a programming example, see Appendix D.

- h. Press the **MON 2** key to exit this loop and return to the View Events screen at the top of the Event Menu.

Class Ends.....



Countdown Duration (5 min. example)

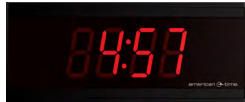

.....Class Begins



3 Programming Special Events

- a. Press **OFF 0** in the Select Weekdays screen.
- b. Press **SUN 1** for Special Event
- c. Change the year if necessary or enter **OFF 0** **OFF 0** **OFF 0** **OFF 0** to indicate all years. Press **OK** bring up the Enter Event Month screen.
- d. To change the month, enter the number of the month as 2 digits. Enter **OFF 0** **OFF 0** to select all months. Press **OK** to accept and bring up the Choose screen.

2c

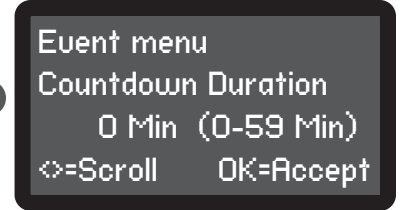

2d

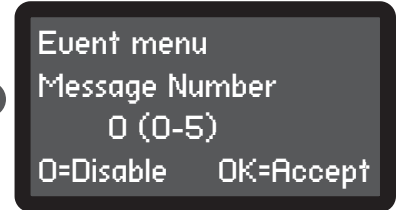

2e

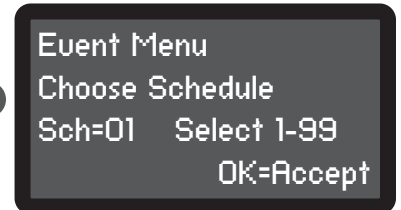

2f



2g

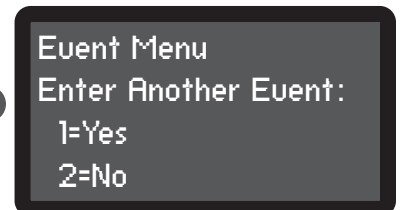

2e

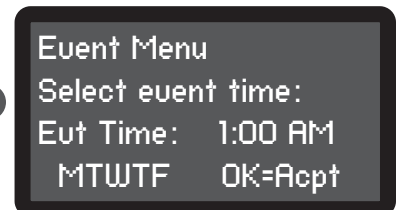

3a



3b

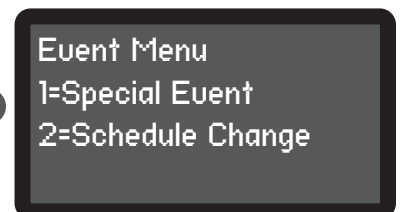

3c

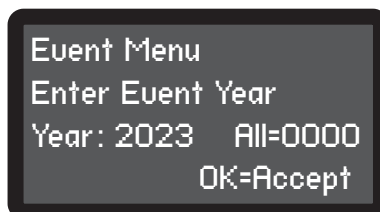

3d

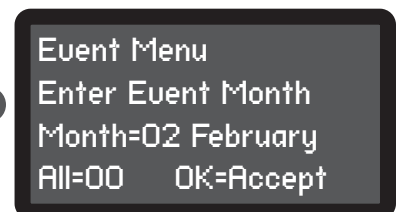



Wired Signal Circuit Option

Programming Special Events (continued)

- e. Press **SUN 1** to select a day of the month and bring up the Select Event Date screen.
- f. Enter a 2-digit day of the month or **OFF 0** **OFF 0** for all days and press **OK**.
 - Pressing **MON 2** in the Choose Screen (3e) brings up the Select Day screen.

At this screen:

- Press **SUN 1** - **SAT 7** keys to add or remove days individually, or
- Press **AUTO 8** to add weekdays, **ADJ 9** to add weekends.
- Press **OK** to accept the assigned days.
- g. The Select Event Time screen appears. To program start time, use the number keys to enter hour and minute.
 - Press **PREV <** for AM or **NEXT >** for PM.
 - Press **OK** to accept the event start time.

The Event Duration screen appears. To program event duration (1-9 seconds):

- h. Press any number **SUN 1** - **ADJ 9** to specify duration, or
 - Press **OFF 0** to use the default duration(s) for the circuit(s) assigned to the schedule, or
 - Press **NEXT >** to latch assigned circuits on until a later event turns them off, or
 - Press **PREV <** to turn off assigned circuits that were previously turned on.
 - Press **OK** to accept event duration.

The Countdown Duration screen appears:

- i. Enter the countdown duration using the keypad or the **PREV <** **NEXT >** scroll keys. Press **OK**.
 - **Note:** This countdown duration is only applicable if you have an SQDxxxxxC(1-6) digital clock. A countdown duration of 0 disables this feature.

The Message Number screen appears:

- j. Enter the message number (see Page 24) using the keypad. Press **OK**.
 - **Note:** This message number is only applicable if you have an SQDxxxxxC(1-6) digital clock. A message number of 0 disables this feature.

The Choose Schedule screen reappears:

- k. Press **OK** to accept the schedule number.
- l. The Event Saved screen briefly appears followed by the Select Event Time screen.

To see a programming example, see Appendix D.

3e

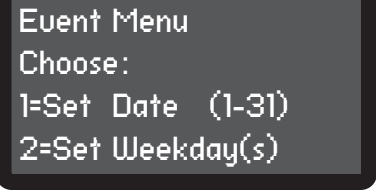

3f



3g



3h

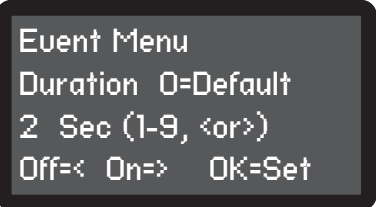

3i

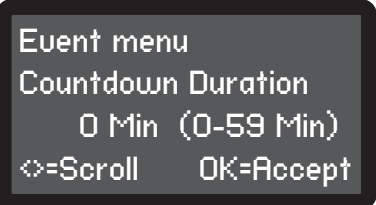

3j

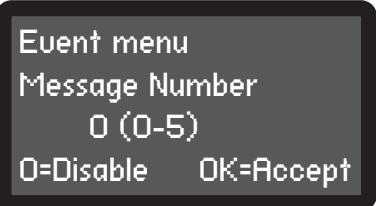

3k

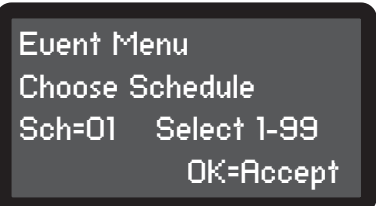

3l



Wired Signal Circuit Option



Press **BACK** to exit the Event Menu.

4 Programming Schedule Change Events

- a. Press **OFF 0** in the Select Weekdays.
- b. Press **MON 2** for Schedule Change.
- c. Change the year if necessary or enter **OFF 0 OFF 0 OFF 0 OFF 0** to indicate all years. Press **OK** to bring up the Enter Event Month screen.
- d. To change the month, enter the number of the month as 2 digits. Enter **OFF 0 OFF 0** to select all months. Press **OK** to accept and bring up the Choose screen.
- e. Press **SUN 1** to select a day of the month and bring up the Select Event Date screen.
- f. Enter a 2-digit day of the month or **OFF 0 OFF 0** for all days and press **OK**.
 - Pressing **MON 2** in the Choose Screen (4e) brings up the Select Day screen.

At this screen:

- Press **SUN 1** - **SAT 7** keys to add or remove days individually, or
 - Press **AUTO 8** to add weekdays, 9 to add weekends.
 - Press **OK** to accept the assigned days.
- g. The Select Event Time screen appears. To program start time:
 - Use the number keys to enter hour and minute.
 - Press **PREV <** for AM or **NEXT >** for PM.
 - Press **OK** to accept the event start time.

The Change Schedule screen reappears:

- h. Press the 2-digit schedule number of the schedule to change to. Press **OK** to accept the schedule number.
- i. The Event Saved screen briefly appears followed by the Enter Another Event

4a
 Select Weekdays:
 8=M-F MTWTF
 9=S+S Key 1234567
 0=Special OK=Accept

4b
 Event Menu
 1=Special Event
 2=Schedule Change

4c
 Event Menu
 Enter Event Year
 Year: 2023 All=0000
 OK=Accept

4d
 Event Menu
 Enter Event Month
 Month=02 February
 All=00 OK=Accept

4e
 Event Menu
 Choose:
 1=Set Date (1-31)
 2=Set Weekday(s)

4f
 Event Menu
 Select event date
 Day of month= 15
 All=00 OK=Accept

4g
 Event Menu
 Select event time:
 Eut Time: 12:00 AM
 MTWTF OK=Acpt

4h
 Event Menu
 Change Sch 01 To
 Sch=02 Select 00-00
 OK=Accept

4i
 Event Menu
 Change Schedule
 JUN 02 2023 12:00AM
 Event 0000 Saved



Wired Signal Circuit Option

screen.

Press **BACK** exit the Event Menu.

5 Reviewing and Editing Events

- m. Press: **PROG** **MON 2**, enter User Lock (unless disabled) using the keypad and press **OK** (unless User Lock is disabled) to enter the Event Menu.

From here:

- Press 1 to add, view, edit or delete events sequentially by event number in a particular schedule, or
- Press 2 to view, edit or delete events in all schedules, beginning with the first event scheduled to start on or after a specified hour, or
- Press 3 to view, edit or delete events by weekday.

6 Reviewing and Editing Events by Schedule

- a. From the "View Events by" screen (4), press **SUN 1** to select Schedule/Event screen.
- Key in a schedule number and press **OK**. If there are existing events assigned to the schedule, the days and start time for the lowest numbered event are displayed.
 - Use the **PREV <** and **NEXT >** keys to scroll through screens for all existing events or enter an event number to move immediately to that event.
 - Press **BACK** to exit the Event Menu. Press **MAN** to delete the event. Press **OK** to view the Select Weekdays screen.
- b. This screen shows the days previously assigned to the event. To change event days:
- Press **SUN 1** - **SAT 7** keys to add or remove days individually, or
 - Press **AUTO 8** to add weekdays, or
 - Press **ADJ 9** to add weekends, or
 - Press **OFF 0** to edit a special event (this will lead to the series of screens for defining special events).
 - Press **OK** to accept the assigned day. For recurring events this brings up the Event Time screen.
- c. This screen shows the start time of the event. To change start time:
- Use the number keys to enter hour and minute.
 - Press **PREV <** for AM or **NEXT >** for PM.
 - Press **OK** to accept the event start time. This brings up the Event Duration screen.
- d. To program event duration (1-9 seconds):
- Press any number **SUN 1** - **ADJ 9** to specify duration, or
 - Press **OFF 0** to use the default duration(s) for the circuit(s) assigned to the schedule, or
 - Press **NEXT >** to latch assigned circuits on until a later event turns them off, or
 - Press **PREV <** to turn off assigned circuits that were previously turned on.

5

```
Event Menu
View Events by
1=Schedule/Event
2=Dte/Tme 3=WKD
```

6a

```
Event Menu
Sch=01 Event=0000
2023-02-10 12:04AM
<Sc> M=Del OK=Edt
```

6b

```
Select Weekdays:
8=M-F MTWTF
9=S-S Key 1234567
0=Special OK=Accept
```

6c

```
Event Menu
Select event time:
Evt Time: 12:00 AM
MTWTF OK=Acpt
```

6d

```
Event Menu
Duration 0=Default
2 Sec (1-9, <or>)
Off=< On=> OK=Set
```

Reviewing and Editing Events by Schedule continued on following page.



Reviewing and Editing Events by Schedule (continued)

- Press **OK** to accept event duration.
- Press **OK** to save event changes.

The Countdown Duration screen appears:

- Enter the countdown duration using the keypad or the **PREV** **NEXT** scroll keys. Press **OK**.
 - **Note:** This countdown duration is only applicable if you have an SQDxxxxxC(1-6) digital clock. A countdown duration of 0 disables this feature.

The Message Number screen appears:

- Enter the message number (see Page 24) using the keypad. Press **OK**.
 - **Note:** This message number is only applicable if you have an SQDxxxxxC(1-6) digital clock. A message number of **OFF 0** disables this feature.

To see a programming example, see Appendix D.

7 Reviewing and Editing Events by Date & Time

- Press: **PROG** **MON 2**, enter User Lock (unless disabled) using the keypad and press **OK** (unless User Lock is disabled) to enter the Event Menu. From here:
- Press **MON 2** to access the Chronological Sort screen. The options given are Sort or Cancel Sort. Either selection will go to the Hour screen (**7c**):
- At the Hour screen, indicate the hour to start displaying events in chronological order. Enter the hour as 2 digits in 24 hour format. Example: the earliest programmed event is 5:00 AM; entering **OFF 0** **THU 5** (or an earlier hour) and pressing **OK** leads to screen (**7d**).
- Use the **PREV** and **NEXT** keys to scroll backward or forward through all programmed events. The steps for reviewing and editing selected events are the same as those listed in Reviewing and Editing Events by Schedule with one exception: the event number cannot be used to jump directly to an event.

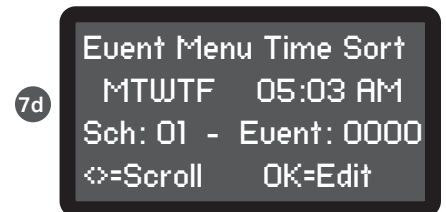
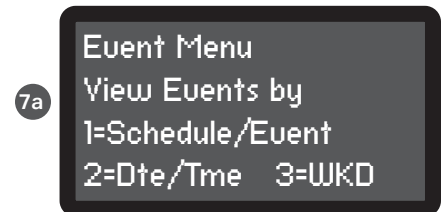
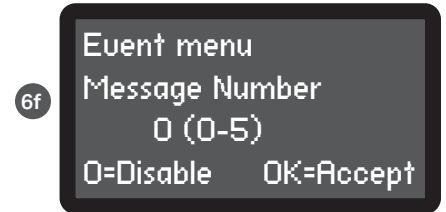
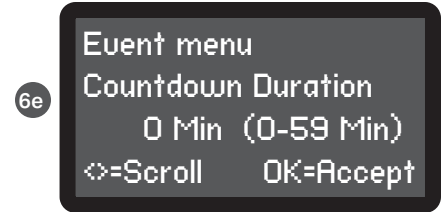

8 Reviewing and Editing Events by Weekdays

- Press: **PROG** **MON 2**, enter User Lock (unless disabled) using the keypad and press **OK** (unless User Lock is disabled) to enter the Event Menu. From here:
- Press **TUE 3** to access the View Weekday screen.
- Select the weekday needed by pressing one of the **SUN 1** - **SAT 7** keys.

Use the **PREV** and **NEXT** keys to scroll through screens showing events scheduled for that day. The steps for reviewing and editing selected events are the same as those listed in Reviewing and Editing Events by Schedule with one exception: event number cannot be used to jump directly to an event.

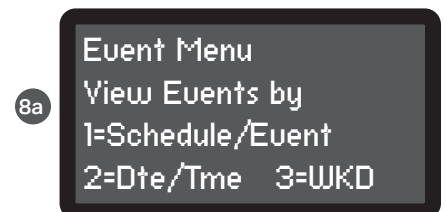



Programming Signal Circuits (Keypad Interface)

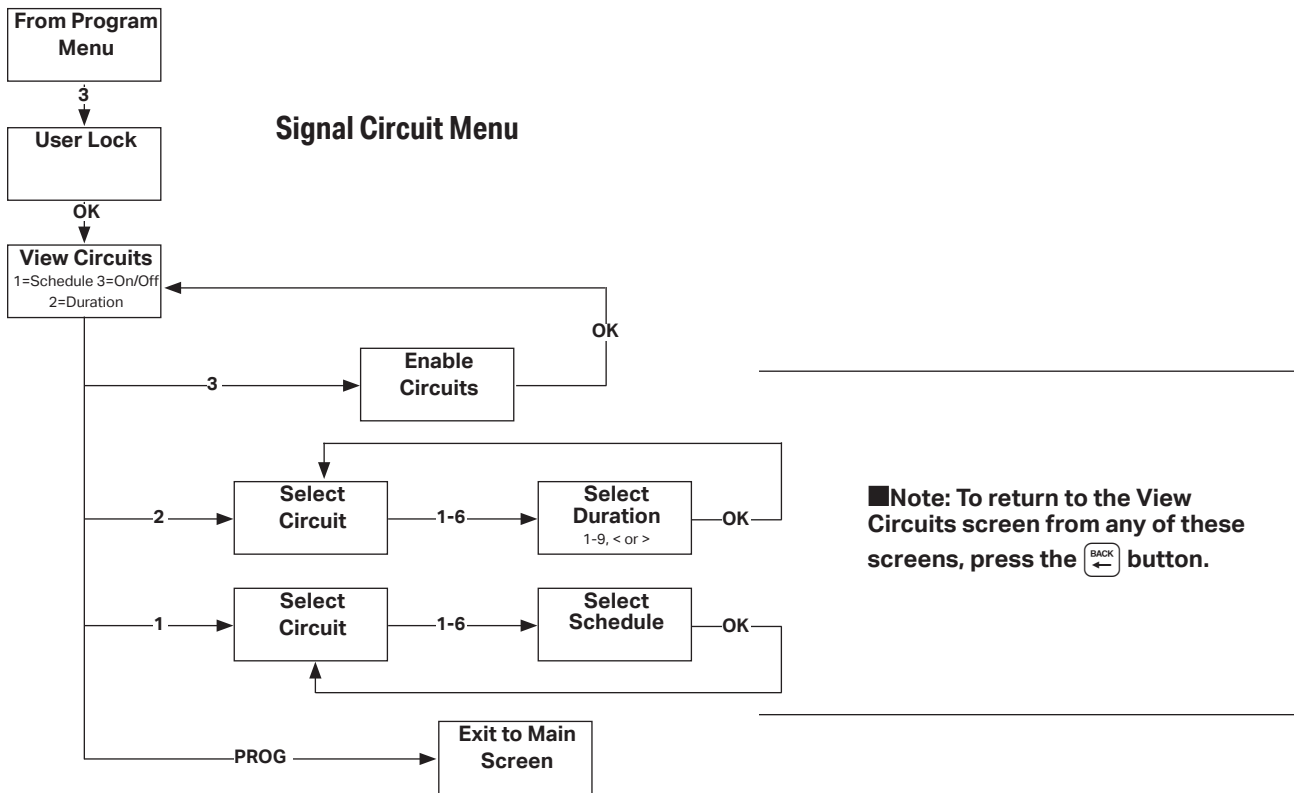

Optional signal relays for controlling signal or lighting circuits must be assigned to schedules of events for automatic control. Multiple circuits can be assigned to one schedule, but each signal circuit can be assigned to only one schedule.

Each signal circuit is also programmed with a default event duration. This allows different signal circuits assigned to the same schedule to be activated for different lengths of time for the same event. For example, a school may have circuit 1 connected to the elementary bells and wish to ring those for 3 seconds. It may have circuit 2 connected to the middle school bells and wish to ring those for 5 seconds. The same events can be assigned to a single schedule but will have different durations on different circuits when using circuit duration defaults. This default duration can be overridden by the duration specified for an event (described in the Programming Events section).

- **Note:** System Controllers with the Ethernet option can also be programmed via the Remote Connect web interface (see page 35).

1 Setting Signal Circuit Schedule and Duration

- Press: **PROG** **TUE 3**. Enter User Lock (unless User Lock is disabled) and Press **OK** (unless User Lock is disabled) to enter Circuit Menu.
- Press **SUN 1** to select the Signal Circuit Schedule Assignment screen. The current schedule assignments for all circuits are shown. To change the schedule assignment for a circuit, press the number of the circuit (i.e. 1).
- Assign a schedule to this circuit by pressing the **NEXT** or **PREV** buttons until the correct schedule is displayed (Pressing 0 disables the circuit). Press **OK** to accept.

This returns you to the Signal Circuit Schedule Assignment screen (b).

- Press **BACK**.
- Press **MON 2** to bring up the Duration screen.

Setting Signal Circuit Schedule and Duration continued on following page.

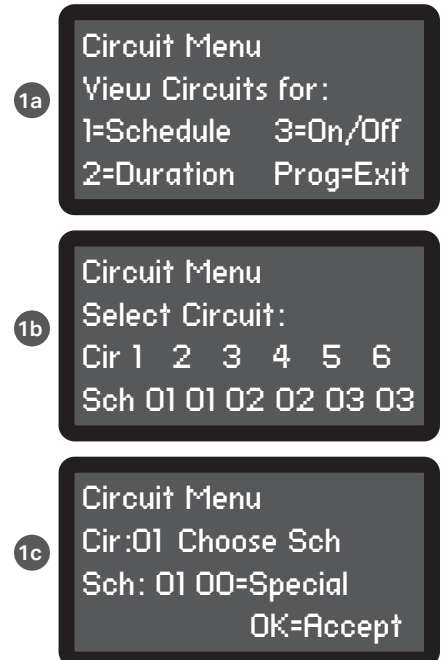



Setting Signal Circuit Schedule and Duration (continued)

- d. This screen shows the current default duration for all circuits. "<" indicates an off default and ">" indicates an on default. To change the default duration for a circuit, press the number of the circuit (i.e. **SUN 1**).
- e. The Select Circuit Duration screen shows the current default duration for the selected circuit. This duration applies only for events that are programmed with a duration of 0. Circuit duration can be for a definite period (1-9 seconds) or for a time defined by two successive events. The first event turns the circuit on, the second event turns it off. To change circuit default duration:
 - Press any number **SUN 1** - **ADJ 9** to specify duration in seconds, or
 - Press **NEXT >** to latch the circuit on, or
 - Press **PREV <** to latch the circuit off.

Pressing any of these options saves the circuit duration and returns to the View Circuits screen **(a)**.

To see a programming example, see Appendix D.

2 Enabling and Disabling Signal Circuits

- a. From the View Circuits screen, press **TUE 3** to enter the Enable Circuits screen to view or change the control status of individual circuits.
- b. For a signal circuit to be controlled by programmed events, it must be enabled (on) and the status of the system controller must be set to AUTO. To set status to AUTO:
 - Press **AUTO 8**, enter User Lock and press **OK**.
- c. Setting the system controller status to OFF disables all signal circuits. To set the status to OFF:
 - Press **OFF 0**, enter the User Lock (unless User Lock is disabled) and press **OK** (unless User Lock is disabled)

3 Controlling Signal Circuits Manually

Signal circuits can be controlled manually with the MAN key acting as a momentary push-button switch. To initiate manual control:

- a. Press **MAN**, enter User Lock (unless User Lock is disabled) and press **OK** (unless User Lock is disabled).
- b. Press any combination of keys **SUN 1** - **FRI 6** to select or deselect the circuits to be turned on with the **MAN** key.

Wired Circuit Activation:

- Press and hold the **MAN** key to activate the selected circuits for the desired length of time.
- Release the **MAN** key.

■ **Note:** When the wireless circuit activation is enabled, the wired activation will have approximately a 3 second delay to account for the wireless transmission.

The **MAN** key can be pressed as many times as needed. Control of the signal circuits reverts to its previous state (AUTO or OFF) upon exiting this menu.

1d

```
Circuit Menu
Select Circuit:
Cir 1 2
Dur < 1
```

1e

```
Circuit Menu
Select Cir 1 Duration
5 Sec (1-9, <or>)
Latchin Off=< On=>
```

2a

```
Circuit Menu
View Circuits for:
1=Schedule 3=On/Off
2=Duration Prog=Exit
```

2b

```
Circuit Menu
Enable Cir: OK=Done
1=On 2=On 3=On
4=On 5=On 6=On
```

3b

```
Manual Signal TX
Select Cir: 0=W/L 7=All
Circuit: 1234567
Man=Signal OK=Exit
```



Wireless Circuit Activation:

- Press **OFF 0** to enable wireless circuit activation. Press **MAN** to activate the selected circuits for the default duration of circuit 6.
- **Note:** Reference Setting Signal Circuit Schedule and Duration on Page 29 to change the default duration of circuit 6.
- **Note:** Upon pressing M, a TX will appear in the upper right hand corner to signify that the wireless activation is being transmitted.
- **Note:** The wired circuit will be delayed in this mode.

For circuits configured for ON/OFF operation:

If the default duration for a circuit being activated with the MAN function is currently configured to ON or OFF (in the Circuit Durations Menu) the circuit will toggle states when pressing the MAN key. This feature can be used to turn on lights after a power outage. For example, parking lot lighting is set up on Circuit 6 with a continuous ON event at 10:00pm, and an OFF event at 6:00am. The power goes out due to a thunderstorm at 2:00am and comes back on at 3:00am. These parking lot lights will be off, since the unit was reset. To turn them back on after 3:00am, you can activate circuit 6 via the MAN button, as described on the previous page. The lights will then stay on until the OFF event at 6:00am.

Automatically switching assigned schedules for a circuit:

This feature allows for programming of a schedule change on any circuit. This may be handy for setting a holiday schedule, for example.

To program an automatic schedule change:

1. Press: **PROG TUE 3** Enter User Lock (if applicable), then press **SUN 1**. The circuit schedule assignments screen will display.
2. Press circuit (1-6) you wish to set automatic schedule change for.
3. Press **MAN** button to enter a schedule change.
4. Option **SUN 1** and **MON 2** are schedule replacements. This allows for reverting back to the current schedule at a later date.
5. Select **SUN 1** or **MON 2**. In this screen, use the **PREV <** **NEXT >** keys to select the schedule to change to. Press **OK**.
6. In this screen, enter the date with the keypad. Press **OK** after entry of each field to advance. For example, press **OK** after entering the year to advance to the month field. AM/PM can be selected with the **PREV <** **NEXT >** keys. Press **OK** when date and time have been entered.
7. Repeat these steps for another schedule change on this circuit. Choose option **MON 2** if option **SUN 1** was initially set or vice versa. These options will occur chronologically by the date and time entered for each.

To see a programming example, see Appendix D.

2

```
Circuit Menu
Select Circuits      1
Circ 1 2 3 4 5 6
Sch 01 01 04 -- -- --
```

3

```
Circuit Menu
Circuit 1 : Sch 01
MAN=Timed Sch Change
<=>=Scroll   Ok=Accept
```

4

```
Circuit Menu
Timed Sch Change for
Circuit 1 : Sch 01
1=Sch05      2=Empty
```

5

```
Time Sched Change to
Sch:05 on 2023-10-31
          at 08:00 AM
<=>=Scroll   OK=Next
```

6

```
Time Sched Change to
Sch:05 on 2023-10-31
          at 08:00 AM
<=>=AM/PM   OK=Next
```

Contact Closure Sync Option

Installing Contact Closure Sync Option

This option allows a SiteSync IQ System Controller to be synchronized with existing equipment with a contact closure. This type of synchronization can also be implemented between two SiteSync IQ System Controllers.

Existing Equipment Providing 2 Wire Synchronization

This option uses the existing system with contact closure (i.e. Phone/Intercom System, Master Clock, Synchronizer, etc.) to synchronize a SiteSync IQ System Controller. Connect wiring as shown in the diagram at right.

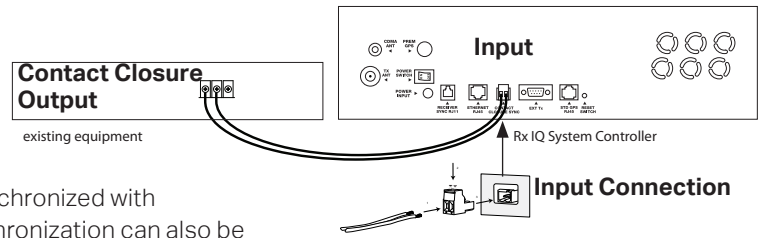

Programming Procedure

Turn on the power to the System Controller

- 1 To set the SiteSync IQ System Controller to be a receiver (Rx) of the contact closure. Press **PROG** **ADJ 9** to enter Master to Master Menu.
- 2 Enter User Lock. Press **OK**.
- 3 Press **MON 2** to set the SiteSync IQ System Controller to Rx.
- 4 Using the keypad, set the time when the existing equipment performs a contact closure. Use **PREV** **NEXT** to select AM or PM. Press **OK**.

Note: Reference existing equipment instruction manual for contact closure time.

SiteSync IQ System Controller providing 2 Wire Synchronization (refer to screen shots above)

This option uses a SiteSync IQ System Controller to sync existing equipment supporting contact closure input. Connect wiring as shown in the diagram below.

Turn on the power to the System Controller

- 1 Set the SiteSync IQ System Controller to be a transmitter (Tx) of the contact closure. Press **PROG** **ADJ 9** to enter Master to Master Menu.
- 2 Enter User Lock. Press **OK**.
- 3 a. Press 1 to set the SiteSync IQ System Controller to Tx.
b. Enter transmit duration in milliseconds (0-9999). Press **OK**.
- 4 Using the keypad, set the time when the contact closure should occur. Use **PREV** **NEXT** to select AM or PM. Press **OK**.
 - **Note:** Reference existing equipment instruction manual for contact closure time. These closure time and duration settings are also used for the wireless Master Synchronizer (optional, ATS Part # H004228).
 - **Note:** Wireless Master Synchronizer transmissions round up to the nearest second. Example: 2,005ms = 3 seconds
 - **Important:** The Sync Time set in Step 4 must be the same for both units.

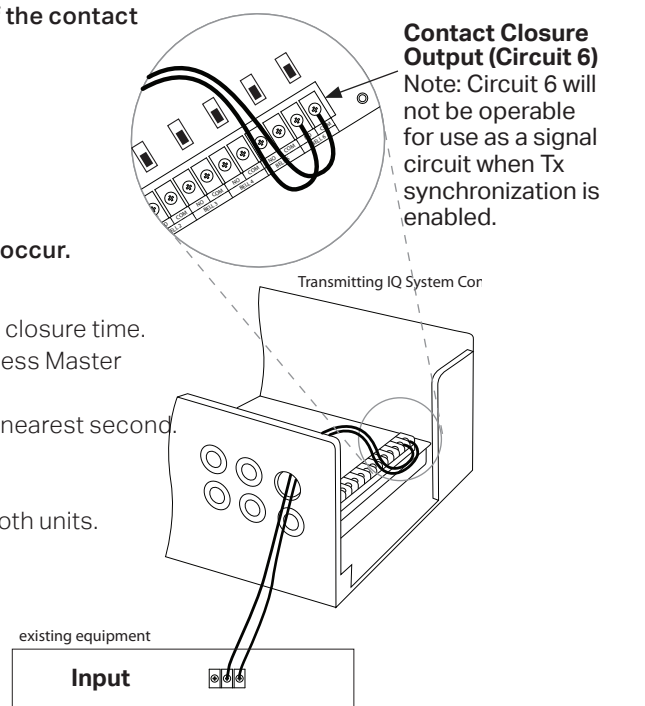
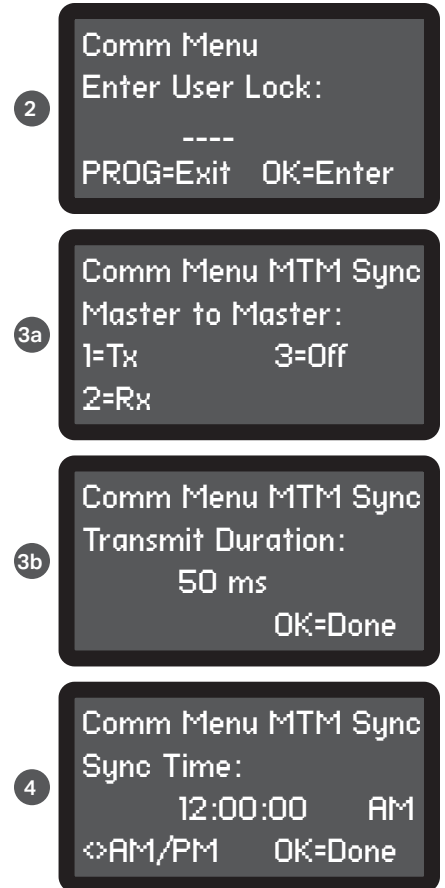

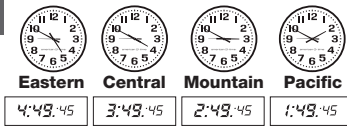

Time Zone Clocks Option

This feature allows for up to 8 additional time zone clocks.

Programming Procedure

Turn on the power to the System Controller

1 Press: **PROG** **SUN 1**. Enter the User Lock. Press **OK**.

2 Press **TUE 3** to enter Time Zones & DST Menu.

3 To select the time zone

a. Use the **PREV** **NEXT** keys to select the time zone to configure (1-8).

0=Local 1=TZ1 2=TZ2 3=TZ3 4=TZ4

5=TZ5 6=TZ6 7=TZ7 8=TZ8

■ **Important:** This feature requires clock receiver configuration by the factory.

b. Select TZONE time zone by using the **PREV** **NEXT** or enter a time zone code from Appendix B. Press **OK**.

If a custom time zone is needed, press **ADJ 9** **ADJ 9** and **OK** and reference Setup Wizard **Step 4** (page 10). Reference Setup Wizard **Step 5** (page 10) to configure DST.

4 Repeat Steps 1-4 for additional time zone clocks.

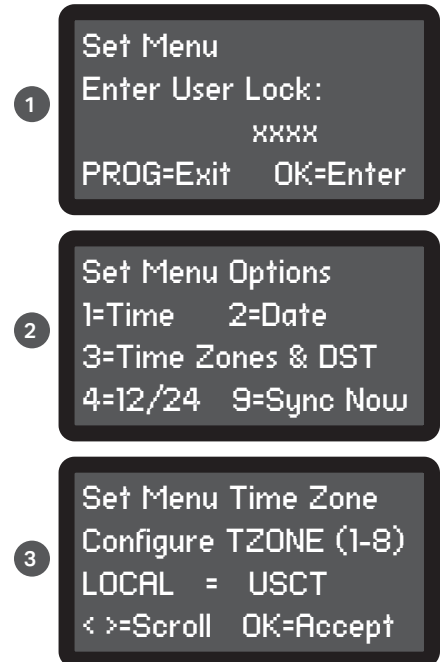

Time Zone Clocks Example:

These examples will demonstrate how to set up two time zone clocks. This feature requires clock receiver configuration by the factory. The first clock will be set as TZONE1 and will be set to represent London Time (UTC+0). The second clock will be set as TZONE2 and will be set to represent Tokyo time (UTC+9).

Clock TZONE1:

1. Press **PROG** **SUN 1** and enter User Lock (if applicable).
2. Press **TUE 3** to enter Time Zone & DST.
3. Use **PREV** **NEXT** keys to select TZONE1 and press **OK**.
4. Use the **PREV** **NEXT** keys to select Time Zone Code 14 (UTC+0) or use the keypad to enter 14 and press **OK**.
 - **Note:** Reference Appendix B for supported time zones.
5. Press **ADJ 9** for Custom DST settings and press **OK**.
6. Press **MON 2** for Floating Dates.
 - **Note:** In the European Union, Summer Time begins at 1:00 AM Universal Time (UTC) and ends at 2:00 AM Summer Time 1:00 AM UTC). It begins the last Sunday in March and ends the last Sunday in October. In the EU, all time zones change at the same moment.
7. Select LAST SUN of MAR using the **PREV** **NEXT** keys and pressing **OK** between selections.
8. Set the BIAS to +1:00 by pressing: **SUN 1** **OFF 0** **OFF 0** **OK**. Press **OK** to accept.

9. Enter the DST Start Time **SUN 1** **OFF 0** **OFF 0** and select AM using the **PREV** **NEXT** keys. Press **OK**.
10. Select LAST SUN of OCT using the **PREV** **NEXT** keys and pressing **OK** between selections. Press **OK** to accept.
11. Enter the DST End Time **MON 2** **OFF 0** **OFF 0** and select AM using the **PREV** **NEXT** keys. Press **OK**.

TZONE1 is now configured. Any wireless clocks configured for TZONE1 will correct to London time on power-up or reset.

Clock TZONE2:

1. Use the **PREV** **NEXT** keys to select TZONE2 and press **OK**.
2. Use the **PREV** **NEXT** keys to select Time Zone Code 23 (UTC+0) or use the keypad to enter **MON 2** **TUE 3** and press **OK**.
 - **Note:** Reference Appendix B for supported time zones.
3. Press **OFF 0** for turning DST off.
 - **Note:** Japan does not have DST.
4. Press **OK**.

TZONE2 is now configured. Any wireless clocks configured for TZONE2 will correct to Tokyo time on power-up or reset.

The Remote Connect Web Interface allows remote access to your SiteSync IQ system controller via a web browser. This includes Event and Circuit programming, manual circuit activation, time/date settings and other system configurations.

This feature is available to all SiteSync IQ System Controllers with the Ethernet option.

- **Note:** Ensure that you have the most current web browser (ie. Firefox, Internet Explorer, Chrome, Edge, Safari)

To access Remote Connect:

1. Ensure that the SiteSync IQ System Controller installation has been performed (page 6) and that the Ethernet option has been configured (pages 18-19)
2. Open a web browser. Enter the IP address for your system controller (#4 on page 18) as `http://xxx.xxx.xxx.xxx` or `ssiq` plus last six digits of MAC address if DHCP is Enabled in the web browser's Address field (**Figure 1**). Press the **Enter** key.



or



Figure 1

- **Note:** If using DHCP Host Name, the network or computer connected to the system controller for configuration must be on the same Subnet for Host Name to work properly
3. A User Login window, (**Figure 2**) will appear. There are two available user names, `uclock` and `sclock`, which represent the user and service access levels. The user security level allows access to everything but the Configuration Tab.
 - User Level Access:
 - Enter **uclock** in lowercase letters in the User Name field and **uclock** in the Password field. This is a user login which will allow access to time/date and event menus.
 - Service Level Access:
 - Enter **sclock** in lowercase letters in the User Name field and **sclock** in the Password field. This is a service login which will allow access to all menus.
 - **Note:** Passwords may be changed in the Configuration Tab.
 - Then, click the **Login** button.

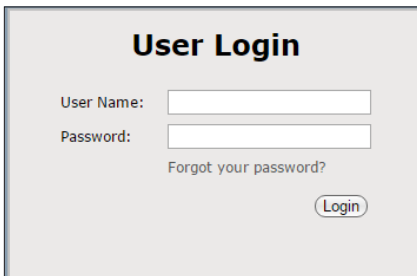

Figure 2

4. The Remote Connect utility will appear with the General tab selected. The tabs displayed may differ depending on the configuration of the unit.

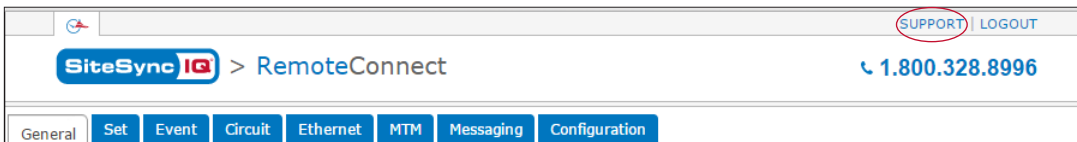

Figure 3

For more details on the features of Remote Connect, click on the Support link in the upper right-hand corner of the utility (Figure 3).

General Tab:

The **General Tab** contains information about the system controller as well as manual correction options for systems with clock relays.

Figure 4

1. **Clock Code** – This allows the user to see which clock code is currently selected to run their wired clocks. If the text is cut off, hover over with mouse to see full text. This field may not be selectable if the system controller is not configured for clock relays.
2. **Circuit Status** – This will enable the bell relays if set to AUTO. This field may not be selectable if the system controller is not configured for bell relays.
 - **Note:** Scheduled events will not run if this is not set to AUTO.
3. **Device Name** – This allows the user to name the system controller. This is useful for users that have more than one SiteSync IQ system controllers to manage.
 - **Note:** Changing the Device Name requires Service-level access.
4. **Time Last Set** – This will display the last date and time the system controller was set. The source of which the date and time was set will also be displayed.
 - **Note:** Ethernet 1 is the Primary Ethernet time server and Ethernet 2 is the Alternate time server as seen on Ethernet tab page 41.
5. **Software Version** – This will display the current software version of the SiteSync IQ system controller.
6. **Serial Number** – This is the serial number of the SiteSync IQ system controller.
7. **Unit Configuration** – This is the configuration code of the SiteSync IQ system controller.
8. **Model Number** – This is the model number of the SiteSync IQ system controller.
9. **Call Sign** – This is the call sign used by the SiteSync IQ system controller.
10. **Previous/Next Signal** – This will display the next circuit activation to occur.
11. **Quiet Mode** – This will display when the SiteSync IQ system controller enters Quiet Mode. Please reference Appendix J for more information on Quiet Mode.
12. **Last Powered ON** – This will display when the SiteSync IQ system controller was last turned on. This is useful to determine if the unit has lost power.
13. **Battery Low** – This indicates that the internal timekeeping battery need to be replaced. See Troubleshooting Section page 51 for more information.

Clock Codes:

Synchronous – If the system is to operate with synchronous clocks and the synchronous clock code is selected, the Manually Adjust Synchronous Clocks box will appear. For example, setting the Clock Code selector to 1 will enable synchronous clock operation.

- Pressing the 1 Hour button will advance the clocks by 1 hour. There will be approximately a 1-2 minute delay for each 1 Hour button press to allow the clocks to adjust.
- Pressing the 12 Hour button will advance the clocks to the configured 12 hour mark. There will be a maximum delay of 13 minutes for each 12 Hour button press to allow the clocks to adjust.

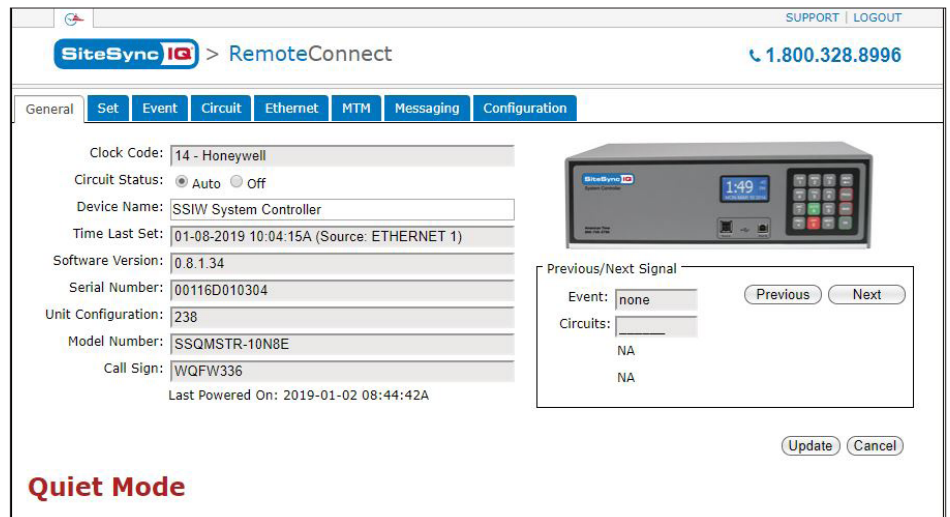
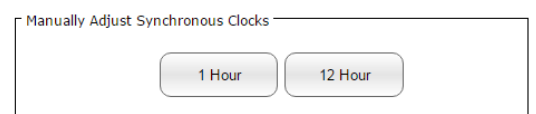

Figure 5



Impulse – If the system is to operate with impulse clocks and an impulse clock code is selected, the **Manually Adjust Impulse Clocks** box will appear. For example, setting the **Clock Code** selector to 2 will enable impulse clock operation.

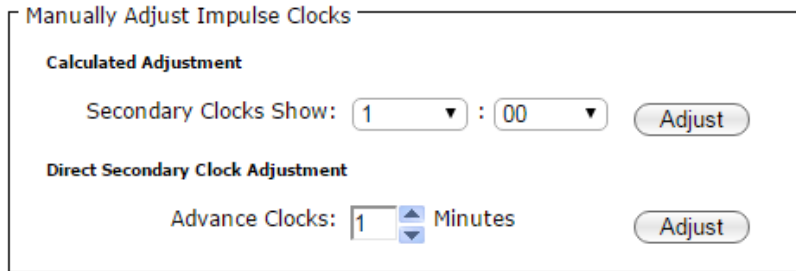

Figure 6

- The **Calculated Adjustment** will automatically adjust the impulse clocks to the correct time. Just enter the time that is shown on the impulse clocks and press Adjust. The number of impulses necessary to adjust the clocks will automatically be sent to the clocks.
- The **Direct Secondary Clock Adjustment** will allow for a specific time advancement in minutes. Therefore, entering the number of minutes of advancement and pressing Adjust will send the corresponding number of impulses to the clocks.

Set Tab:

The Set Tab allows you to set the time zone, daylight saving time, date, and time for your local clocks and time zone clocks.

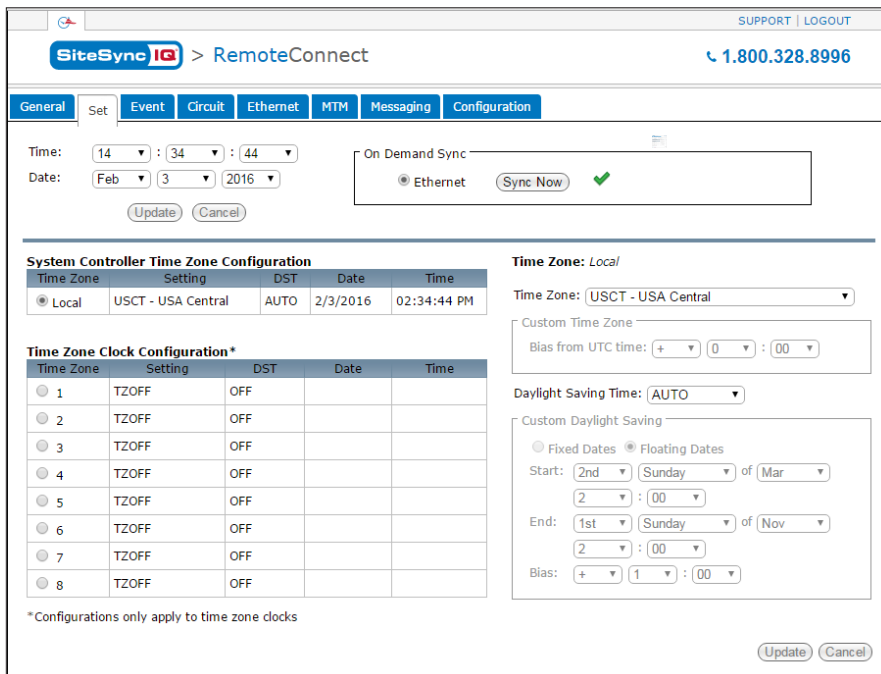

Figure 7

1. **Time:** This allows the user to set the time in the following format HH:MM:SS. After selecting a time change, the Update button must be pressed to take effect.
 - **Note:** Time will always be in military time.
2. **Date:** This allows the user to set the date. After changing the date, the Update button must be pressed to take effect.
3. **On Demand Sync:** The synchronization options configured on the system controller will be displayed. The user may choose the option in which they would like to synchronize their time and press Sync Now. The time and date will be updated automatically if successful.
 - ✓ indicates a successful sync.
 - ✗ indicates a failed sync.

4. System Controller Time Zone Configuration: When this is selected, the Time Zone and Daylight Saving Time settings can be configured. The Update button in the lower right hand corner must be pressed for any changes to take effect.
 - Time Zone: This drop down contains a list of all time zones.
 - Daylight Saving Time: This drop down contains AUTO, CUSTOM, or OFF.
5. Time Zone Clock Configuration: There are 8 selectable time zone clocks. Each time zone clock can be configured to a time zone and DST. The Update button in the lower right hand corner must be pressed for any changes to take effect.
 - Time Zone: This drop down contains a list of all time zones.
 - Daylight Saving Time: This drop down contains AUTO, CUSTOM, or OFF.

Event Tab:

The Event Tab allows you to create, edit, print, and save your schedules.

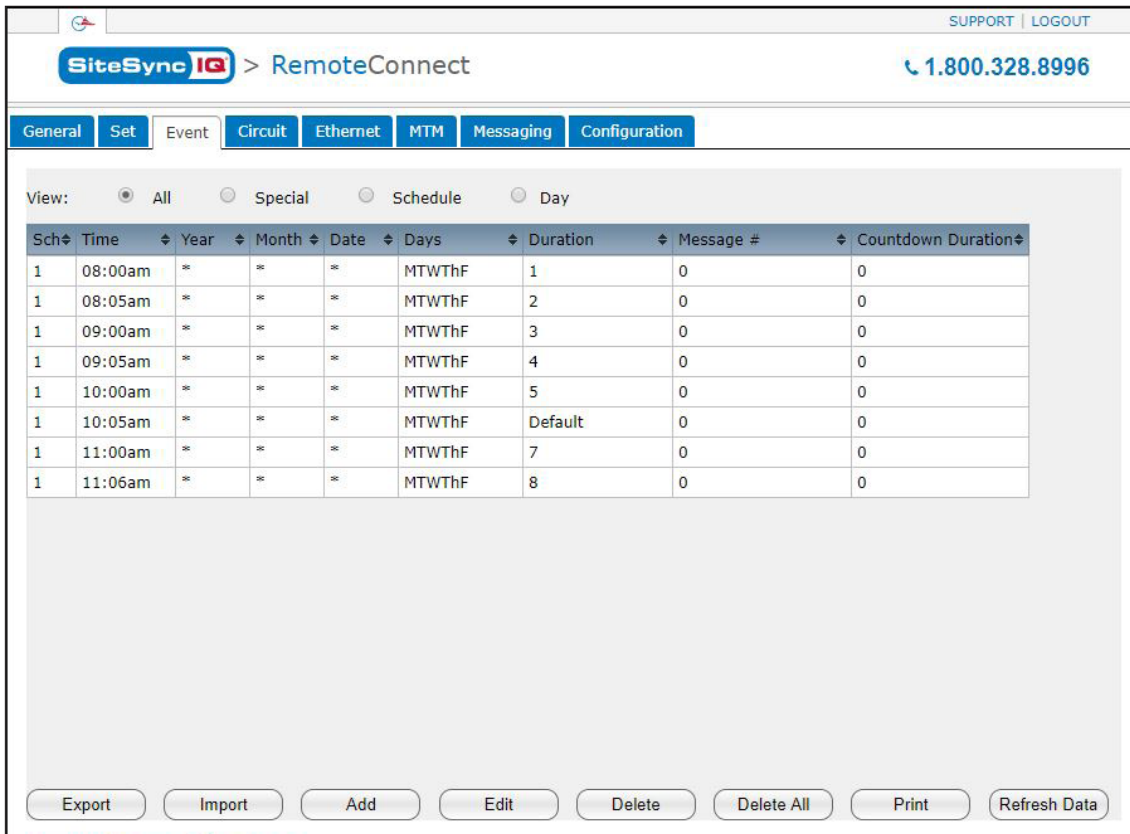

Figure 8

1. **View:** This row is for sorting which events should be displayed in the table below. If Schedule or Day is selected an additional drop down will appear for selection.
 - **Note:** Press the Refresh button to update the table.
2. **Export:** This allows the user to export their schedules to a .ats file for backup.
3. **Import:** This allows the user to import an .ats file.

Event Tab continued on following page.

Event Tab (cont):

4. **Add:** This allows the user to add new events to a specified schedule. There are three types of events:
 - Regular Events: A reoccurring day of the week event.
 - Special Events: An event that occurs on a specific time and date.
 - Schedule Change: A planned change of schedule on a specific time and date.

This will prompt the following:

Figure 9

- a. **Schedule:** The current event schedule.
 - b. **Schedule Name:** The name of the selected schedule.
 - c. **Regular Event/Special Event/Schedule Change:** The event type.
 - d. **Special Event Date:** Specific date selection for Special Events or Schedule change Events. Does not appear for Regular Events. Date may not be in the past.
 - e. **Message #:** Message to be displayed on Digital Clocks. Does not apply for Schedule Change Events. Reference Manual Activation section of Remote connect for further details.
 - f. **Countdown Dur:** Countdown timer for Digital Clocks in minutes. Does not apply for Schedule Change Events.
 - g. **Change Schedule To:** Schedule selection to change to. This only appears if a Schedule Change Event is selected.
 - h. **Duration:** Duration of event. Does not apply for Schedule Change Events.
 - i. **Time:** The specified time of the event.
 - j. **Weekdays (M-F)/Weekends (S-S):** Day of the week selector.
 - k. **Accept:** Accept event entry.
 - l. **Cancel:** Cancel event entry.
5. **Edit:** This will prompt the Event Edit window for the event highlighted. This can also be accessed by double clicking on an entered event.
 6. **Delete:** This will delete the highlighted event.
 7. **Delete All:** This will delete all events.
 8. **Print:** This will print the events that are displayed in the table.

Circuit Tab:

The Circuit Tab contains circuit designations to specific schedules. This tab also contains the Manual Activation feature which allows manual activation of relays.

Schedule:

Circuit #	Enabled	Assigned Schedule	Default Duration	Switching 1		Switching 2		Circuit Description Schedule Description
				Schedule	Date/Time	Schedule	Date/Time	
1	<input checked="" type="checkbox"/>	1	3 Seconds	0	NA	0	NA	High School Schedule 1
2	<input checked="" type="checkbox"/>	3	3 Seconds	0	NA	0	NA	Middle School Schedule 3
3	<input type="checkbox"/>	0	3 Seconds	0	NA	0	NA	schedule 0
4	<input type="checkbox"/>	0	3 Seconds	0	NA	0	NA	schedule 0
5	<input type="checkbox"/>	0	3 Seconds	0	NA	0	NA	schedule 0
6	<input type="checkbox"/>	0	3 Seconds	0	NA	0	NA	schedule 0

Update Cancel

american time
Integrated Solutions

Figure 10

- Enabled:** This allows the user to enable or disable the circuit. The circuit must be enabled to run an assigned schedule. The Update button must be pressed for changes to take effect.
- Assigned Schedule:** This is the current schedule assigned to the circuit. The Update button must be pressed for changes to take effect.
- Default Duration:** This is the default duration of the circuit. Events may or may not use this default duration. The Update button must be pressed for changes to take effect.
- Switching 1:** This allows the user to schedule a schedule change. For example, the image above may be a typical example of a winter break schedule. The Update button must be pressed for changes to take effect.
 - Schedule:** This is the schedule that the circuit will switch to at the specified date/time.
 - Date/Time:** This is the date/time in which the schedule for the circuit will switch.
- Switching 2:** This has the same functionality as Switching 1.
- Circuit Description:** This allows the user to name the circuits. The Update button must be pressed for changes to take effect.
- Schedule Description:** This displays the schedule name as defined in the Event Edit window (Figure 9).

Manual Activation:

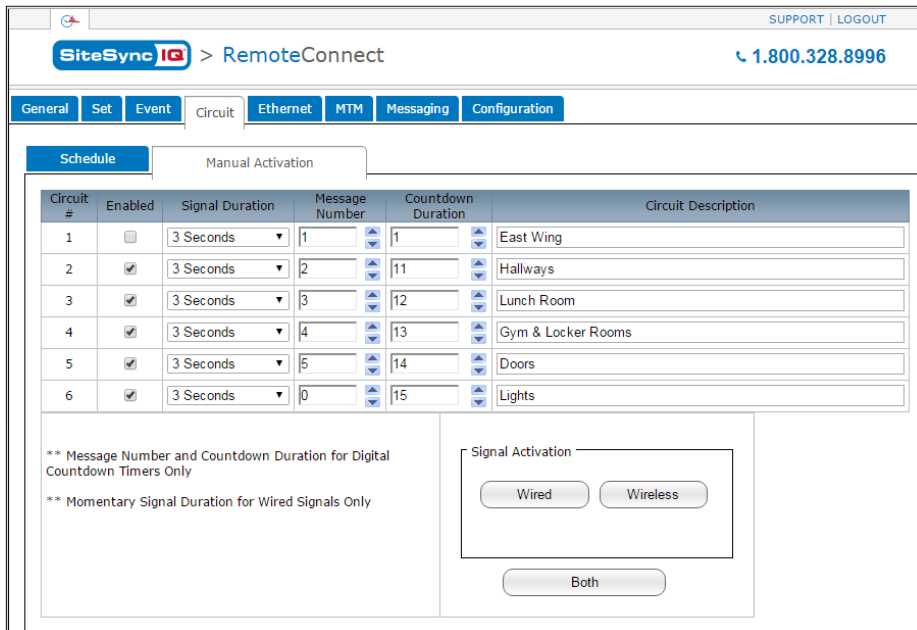

Figure 11

- Enabled:** This allows the user to enable or disable which circuits should be manually activated.
- Signal Duration:** This is the duration which the circuit will manually activate.
 - **Momentary:** The duration Momentary is only used for Wired Signal Activation. This will allow the user to signal the circuit for as long as they hold down the Wired button.
- Message Number:** This is used to select the message that will be displayed prior to a countdown.
 - **Note:** This message number is only applicable if you have an SQDxxxxxC(1-6) digital clock. A message number of 0 disables this feature.

Class Ends.....



Bell rings (3 secs)



Clock counts down from 5 mins



Countdown completes

.....Class Begins



Clock displays real time

- Countdown Duration:** This is used to select the duration of the countdown (0-59 minutes).
 - **Note:** This countdown duration is only applicable if you have an SQDxxxxxC(1-6) digital clock. A countdown duration of 0 disables this feature.
- Circuit Description:** This is the description of the circuit as assigned in the Schedule Tab.
- Wired:** This will signal the wired enabled circuits only for the duration specified in the Signal Duration.
- Wireless:** This will signal the wireless enabled circuits only for the duration specified in the Signal Duration.
 - **Note:** A Momentary Signal Duration cannot be assigned to a wireless signal activation.
- Both:** This will signal the wired and wireless enabled circuits for the duration specified in the Signal Duration.
 - **Note:** A Momentary Signal Duration cannot be assigned to a wireless signal activation.

Ethernet Tab:

The Ethernet Tab contains the network settings for the SiteSync IQ system controller (editable with service-level login).

1. **Ethernet Enable:** This allows the user to choose if the SiteSync IQ system controller should be a client, server, or both (time synchronization).
2. **DHCP:** This is the default Ethernet setting. When this box is checked, the device will automatically obtain an IP address from a DHCP server. The address received will be displayed in the Unit IP Address boxes.
 - **Note:** If no DHCP address is received, the device will default to 192.168.10.10. In this situation, directly connect an Ethernet patch cable from the system controller to a computer that is on the same Subnet. Example: Set the connecting computer IP address to 192.168.10.11. See your Network Administrator if you do not know how to do this. More information is also available in the Ethernet troubleshooting section.

The screenshot shows the 'RemoteConnect' web interface for SiteSync IQ. The 'Ethernet' tab is selected, showing various configuration options. The 'Ethernet Enable' section has 'Client' and 'Server' checked. The 'DHCP' checkbox is unchecked. The 'Unit IP Address' is 192.168.010.171, 'Subnet Mask' is 255.255.255.000, 'Gateway IP' is 192.168.010.099, 'DNS' is 010.111.039.001, 'MAC Address' is 00:11:6D:01:03:04, and 'Port Number' is 80. The 'Time Server' is set to 'Domain Name (DNS)' with the address '0.americantime.pool.ntp.org'. A 'History' box shows 'Packets Received: 599979' and 'Packets Sent: 2246'. There are 'Update' and 'Cancel' buttons at the bottom right, and a 'Reset Packets Rx/Tx' button in the history box.

Figure 12

3. **Unit IP Address:** This displays the IP address of the system controller. These boxes are normally grayed out and can only be changed if the DHCP box is unchecked. After changing all IP fields in the Ethernet Tab, press the Update button to save the configuration.
4. **Subnet Mask:** This displays the subnet mask of the system controller. After changing all IP fields in the Ethernet Tab, press the Update button to save the configuration.
5. **Gateway IP:** This displays the assigned Gateway IP. After changing all the IP fields in the Ethernet Tab, press the Update button to save the configuration.
6. **DNS:** This displays the IP address of the network server.
7. **MAC Address:** This displays the MAC address of the SiteSync IQ system controller. This field can't be changed in Remote Connect.
8. **Port Number:** This Port Number is defaulted to 80 so that Remote Connect can be displayed. This enables the web server.
9. **Time Server:** This displays two time server options, only one can be selected.

The screenshot shows the 'Time Server' configuration section. It has two radio buttons: 'IP Address' (selected) and 'Domain Name (DNS)'. Below are two IP address input fields: 'Time Server IP Address' with the value 129.006.015.029 and 'Alt. Time Server IP Address' with the value 128.138.140.044.

Figure 13

10. **Time Server IP Address:** This displays the IP address of the time server. After changing this field, press the Update button. This is referred to as Ethernet 1 which is displayed under the general tab. Time Last Set: (Source Ethernet 1).
11. **Alt. Time Server IP Address:** This displays an alternate IP address of a time server. After changing this field, press the Update button. This is referred to as Ethernet 2 check is displayed under the General tab, Time Last Set: (Source Ethernet 2).
12. **Time Server DNS Address:** This displays the IP address from a DNS server used for SNTP synchronization (i.e. 0.americantime.pool.ntp.org or time.nist.gov).
13. **History:** This displays a history of the Ethernet activity to and from the Remote Transmitter. This can be reset by pressing the Reset Packets Rx/Tx button.
 - **Note:** When changing these setting in Remote Connect, close your browser and log in again (with the new IP address, if applicable). Use caution when revising these settings, as you could lose connectivity after pressing Update.

GPS Tab:

The GPS Tab contains status information of the GPS antenna. This displays the signal status, signal strength, and the last signal received.

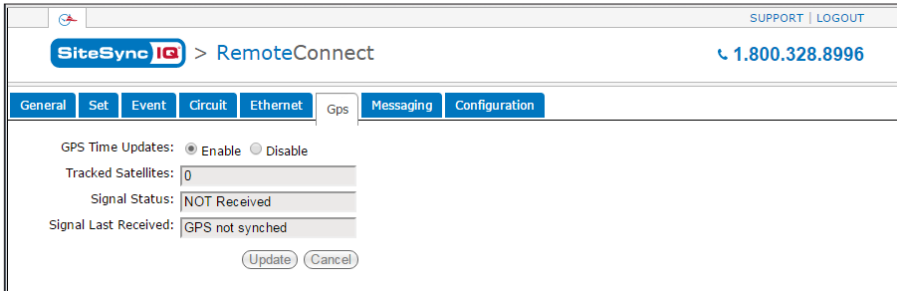

Figure 15

1. **GPS Time Updates:** This allows the user to enable or disable the GPS time synchronization source. The Update button must be pressed for this change to take effect.
2. **Tracked Satellites:** This displays the number of tracked satellites. There should be a minimum of 3 tracked satellites for proper reception.
3. **Signal Status:** This displays if the GPS signal has been received within the last 2 hours.
4. **Signal Last Received:** This displays the date and time of the last GPS signal reception.

Messaging Tab:

The Messaging Tab allows for the entry and storage of 10 pre-canned messages. These messages can be sent to message boards throughout the facility.

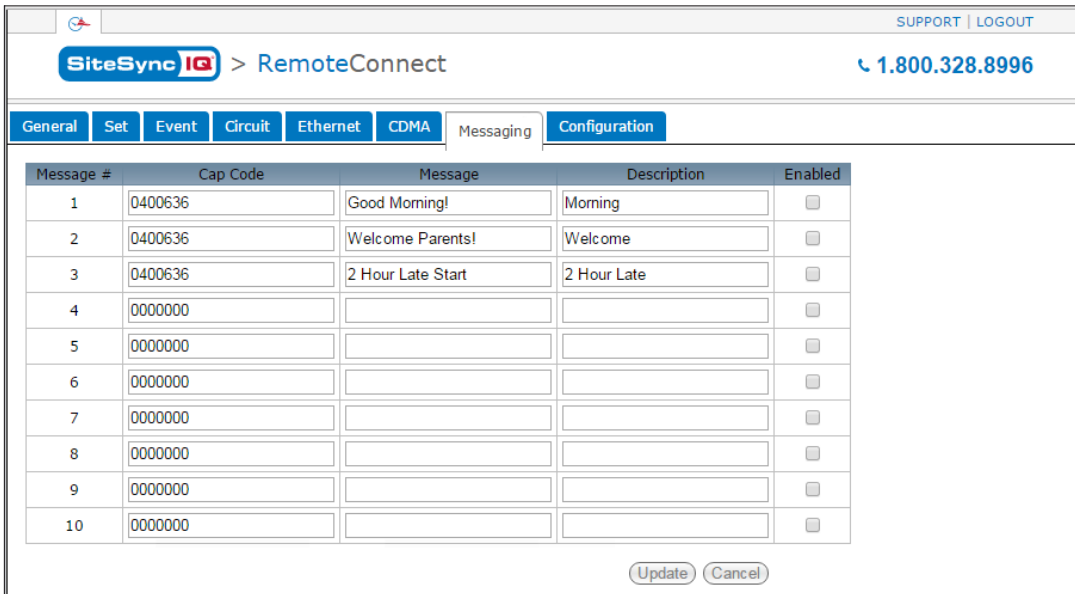

Figure 16

1. **Cap Code:** The Cap Code must be match the Cap Code of the device receiving the message.
2. **Message:** The message entered may need to follow a certain format. Reference the message board reception format.
3. **Description:** This allows the user to enter a description of their message.
4. **Enabled:** Check this box and press Update to transmit the message.

Configuration Tab:

The Configuration Tab requires a service password for access. Within this tab, the user can change their passwords, update their firmware, change their time synchronization priority, change the system controller's banner text or turn Quiet Mode On/Off.

1. **Set Auto DST Dates:** This allows the user to change the AUTO DST dates and times. This allows for future flexibility if the DST were to change. The Update button must be pressed for changes to take effect.
2. **Clock Code:** This allows the user to see which clock code is currently selected to run their wired clocks. If the text is cut off, hover over with mouse to see full text. This field may not be selectable if the system controller is not configured for clock relays.
3. **User Password/Verify:** This allows the user to change the User Password. The User Password must match the Verify Password to be accepted. The Update button must be pressed for changes to take effect.
4. **Service Password/Verify:** This allows the user to change the Service Password. The Service Password must match the Verify Password to be accepted. The Update button must be pressed for changes to take effect.

The screenshot shows the 'Configuration' tab in the RemoteConnect web interface. The page title is 'SiteSync IQ > RemoteConnect' with a support number '1.800.328.8996'. The navigation menu includes 'General', 'Set', 'Event', 'Circuit', 'Ethernet', 'MTM', 'Messaging', and 'Configuration'. The main content area is titled 'Set Auto DST Dates' and contains the following fields and options:

- Start:** 2nd Sunday of Mar @ 2 : 00
- End:** 1st Sunday of Nov @ 2 : 00
- Bias:** + 1 : 00
- Clock Code:** 14 Honeywell
- User Password:** [masked] **Verify Password:** [masked]
- Service Password:** [masked] **Verify Password:** [masked]
- Banner Text:** American Time
- Time Sync Priority:** Ethernet
- Time Display Format:** 12 Hour (selected) 24 Hour
- Manage User Lock:** [masked]
- Manage Service Lock:** [masked]
- Display Size:** Large (selected) Small
- Setup Manager:** Enable (selected) Disable
- Quiet Mode:** On (selected) Off (Temp) Disable

At the bottom, there is a section for 'Update with Latest Firmware' with a 'Browse...' button and an 'Upload New Firmware' button. A 'Reset All Settings' button is located at the bottom left, and 'Update' and 'Cancel' buttons are at the bottom right.

Figure 17

5. **Banner Text:** This allows the user to change the Banner Text displayed on the LCD screen of the system controller. The Update button must be pressed for changes to take effect.
6. **Time Sync Priority:** This allows the user to change the Time Sync Priority. This feature is used to determine the priority of time synchronization of the system controller. The Update button must be pressed for changes to take effect.
7. **Time Display Format:** This allows the user to change the Time Display Format on the LCD screens. The format chosen will also be displayed on our American Digital Series Clocks. The Update button must be pressed for changes to take effect.
8. **Manage User Lock:** This allows the user to change the User Lock for accessing menus through the keypad of the system controller. This lock must be numeric. The Update button must be pressed for changes to take effect.
9. **Manage Service Lock:** This allows the user to change the Service Lock for accessing menus through the keypad of the system controller. This lock must be numeric. The Update button must be pressed for changes to take effect.
10. **Display Size:** This allows the user to change the LCD display size. The Update button must be pressed for changes to take effect.
11. **Setup Manager:** This allows the user to enable the Setup Wizard on a power cycle. If enabled the Setup Wizard will appear on a power cycle. The Update button must be pressed for changes to take effect.
12. **Quiet Mode:** This allows the user to enable Quiet Mode, temporarily turn it off (for 6 hours), or completely disable it. When changing from Disable, the unit will automatically keep Quiet Mode off for 24 hours before turning it back on. The Update button must be pressed for changes to take effect. Reference Appendix J for more details on Quiet Mode.
13. **Update with Latest Firmware:** This allows a user to update the firmware of the system controller. The firmware file must be downloaded from the support site to the PC which is running Remote Connect.
14. **Reset All Settings:** Pressing this button will reset the system controller to factory defaults.
 - **Note:** Pressing this may change the IP address of the unit and it will have to be reconfigured to meet the network specifications.

Manually Setting Time and Date

Press **PROG** **SUN 1** and enter your user lock then **OK** (unless disabled) to access the Set Menu.

1 Manually Setting Time:

- Press **SUN 1**.
 - Enter the hours by pressing the two digit number (i.e. **OFF 0** **FRI 6**). Press **NEXT >**.
- Note:** If 24 hour mode is active, skip to d.
 - Toggle to AM or PM using **BACK <**. Press **NEXT >**.
 - Enter the minutes by pressing the two digit number (i.e. **TUE 3** **OFF 0**). Press **NEXT >**.
 - Enter the seconds by pressing the two digit number (i.e. **WED 4** **THU 5**). Press **OK** when finished.

2 Manually Setting Date

- Press **MON 2**.
- Enter the year by pressing the four digit number (i.e. **MON 2** **OFF 0** **MON 2** **TUE 3**). Press **NEXT >**.
- Enter the month by pressing the two digit number (i.e. **OFF 0** **SUN 1**). Press **NEXT >**.
- Enter the date by pressing the two digit number (i.e. **OFF 0** **SUN 1**). Press **OK** to accept.

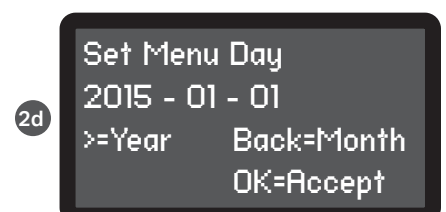
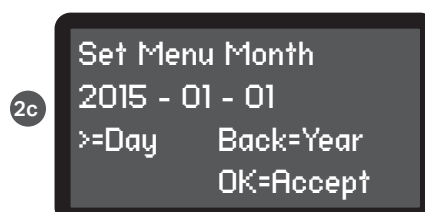
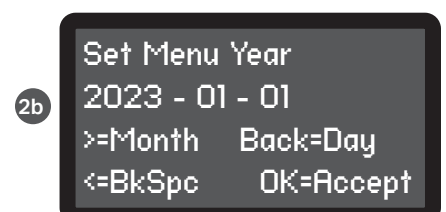
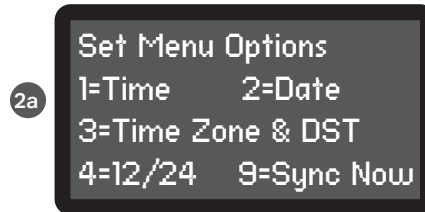
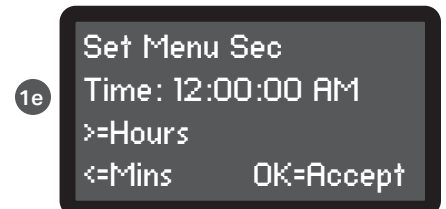
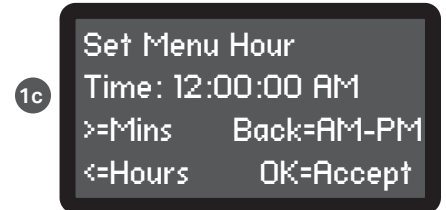
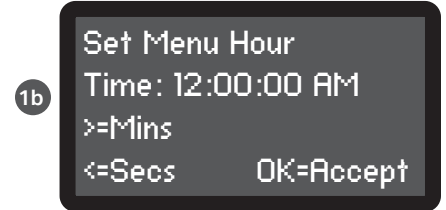
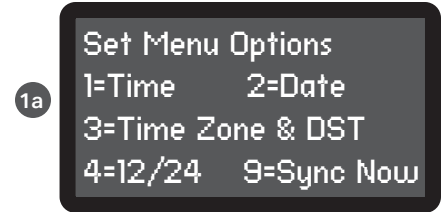

The Config Menu offers the ability to change several settings for the SiteSync IQ Master. Press **PROG** **SAT 7** and enter your service lock to access the Configuration Menu.

3 Manage Locks: From Config Menu press **SUN 1**

- a. User Lock. Press **SUN 1** and enter a new 4 digit User Lock, or Press **OFF 0 OFF 0 OFF 0 OFF 0** to disable this feature.

User Lock:

- Press **OK**
- **Note:** User Lock is the user security level used for accessing time/date and event menus.
- b. Service Lock. Press **MON 2** and enter a new 4 digit Service Lock, or enter **OFF 0 OFF 0 OFF 0 OFF 0** to disable this feature.

Service Lock:

- Press **OK**
- **Note:** Service Lock is the service security level used for accessing System Controller configuration menus.

4 Quiet Mode: From the Config Menu press **MON 2**

This feature is used to enable/disable Quiet Mode. Quiet Mode limits the number of transmissions from the system controller.

- While in Quiet Mode, time messages transmit at HH:07:00 and HH:07:30 every hour
- In addition to the above, time messages also transmit every 30 seconds between 01:49:00-02:00:00 AM & PM and 07:49:00-08:00:00 AM & PM

5 Time Sync Priority: From the Config Menu press **TUE 3**

This feature is used to determine the priority of time synchronization of the System Controller. This screen only displays the sync options that your System Controller supports.

- a. Press the number that corresponds to your time sync priority
- b. Enter the minutes and seconds that the System Controller should attempt to synchronize each hour to the time sync option chosen.

6 Clock Code: From the Config Menu press **WED 4**

This feature is used to set the clock code for wired clock circuits.

- a. Enter the clock code using the keypad
- Press **OK**

7 Clear/Restore: From the Config Menu press **THU 5**

This feature allows for the deletion of all events or restoration of the System Controller to factory defaults.

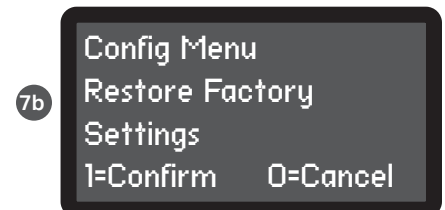
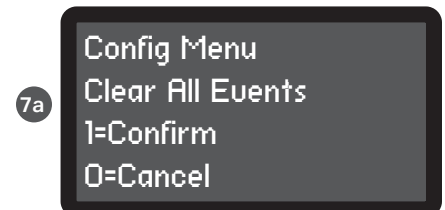
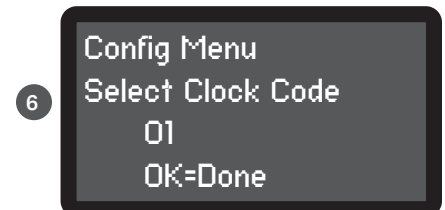
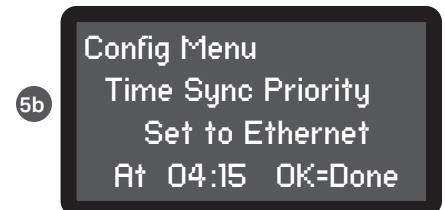
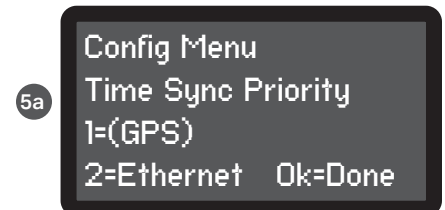
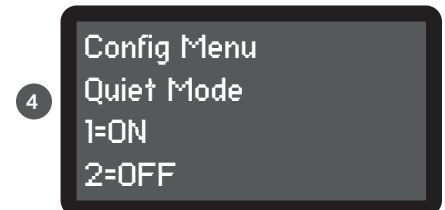
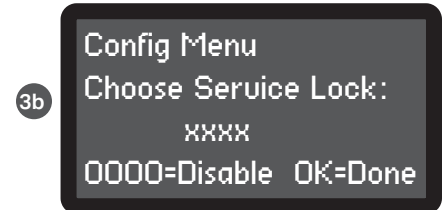
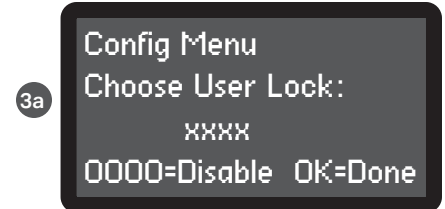

- a. Press **MON 2** to delete all events or **OFF 0** to cancel.
- b. Press **SUN 1** to restore factory defaults or **OFF 0** to cancel.

Config Menu continued on following page.



8 Setup Manager: From the Config Menu press

This feature allows for the enabling and disabling of the Setup Wizard.

- Press  to Enable or  to Disable.
- Press  when finished.



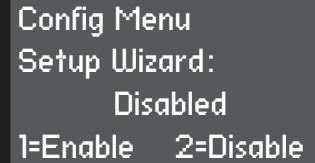

8



```
Config Menu
Setup Wizard:
  Disabled
1=Enable 2=Disable
```

9 Banner Text: From the Config Menu press

This feature allows for the customization of the banner text (up to 20 characters) displayed on the main screen.

- Use  and  to scroll through the available list of characters. Press  to move to the next character.
- Press  when finished.



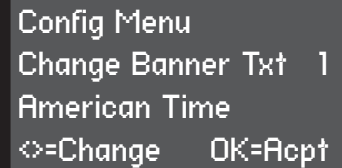



9



```
Config Menu
Change Banner Txt 1
American Time
<=>=Change OK=Acpt
```

10 Display Settings: From the Config Menu press

This feature allows for the display to be presented in a small or large format. The contrast of the screen can also be set.

- Display size: Press  and choose  for large or  for small.
 - Contrast Ratio: Press  and use the  and  keys to change the contrast.
- Press  when finished.

10



```
10:30:06 AM
WED FEB 08 2023
```



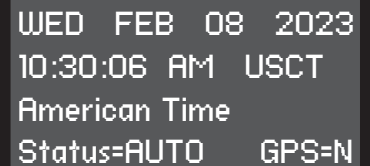





10



```
WED FEB 08 2023
10:30:06 AM USCT
American Time
Status=AUTO GPS=N
```

11 Auto DST Settings: From the Config Menu press

This feature allows the AUTO DST settings to be configured as necessary. This setting does not need to be changed unless the Energy Policy Act of 2005 is amended.

- Start of DST: Use the   keys to choose the starting week, day and month. Press  after each selection. Use the keypad to enter the Bias and the   keys to set the "+/-".
 - End of DST: Use the   keys to choose the ending week, day and month. Press  after each selection.
- Press  when finished.

11a

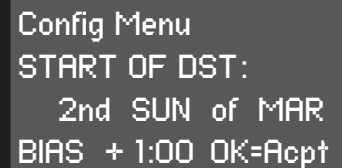

```
Config Menu
START OF DST:
  2nd SUN of MAR
BIAS + 1:00 OK=Acpt
```

11b

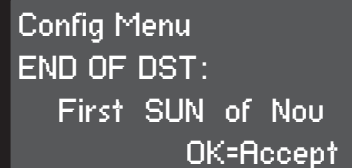

```
Config Menu
END OF DST:
  First SUN of Nov
  OK=Accept
```

12 USB Flash Drive

Refer to Appendix F for instructions on updating the software on the SiteSync IQ system controller.

For both battery and AC clocks, we recommend first installing one clock near the master and then one at the furthest location. Then install the remaining clocks in their designated locations. This will simplify system troubleshooting.

Clocks should be installed within 24 hours of installing the system controller. After 24 hours, the system controller will enter Quiet Mode. Pressing 3-5-7 on the keypad will disable Quiet Mode for 6 hours. Reference Appendix J for more details on Quiet Mode.

Wireless Analog AA Battery Clocks (DC)

Before installation, ensure the gear locking pin (located in the center on the back of the clock) has been removed from the movement.

- **Note:** SiteSync IQ clocks ship with batteries installed. **Do not connect the barrel jack plug to the receiver until the master is installed and transmitting.**

1. Connect the barrel jack plug of the battery pack to the wireless receiver.
2. The LED on the back of the clock will turn red for 1 second then briefly flash orange (1-15 flashes) indicating the receive frequency on power up. Within 30 seconds of power up the LED will flash red or green. Red indicates the receiver is looking for the signal and green indicates the signal has been received. When the movement starts to correct, the LED will turn off.

- **Note:** If the LED does not flash within 30 seconds, remove barrel jack plug of the battery pack from the receiver, wait for 5 seconds and reconnect it. The LED should begin flashing within 30 seconds.

3. Within 2 minutes after activation, the green LED will stop flashing and the clock hands should rapid advance to the correct time. If clocks do not synchronize within 10 minutes of battery activation.
 - See **Note** in step 2.

4. Hang the clock using the keyhole hanger on the back of the clock or the security bracket (sold separately).

5. Continue clock installation. Follow steps 1-4 for the remainder of your clocks. You may skip step 3 and confirm clock synchronization after some or all clocks have been hung.

- **Note:** Clocks will only attempt to sync to the System Controller at approximately 2 (am & pm) and 8 (am & pm) **as displayed on the clocks** and after initial power up.

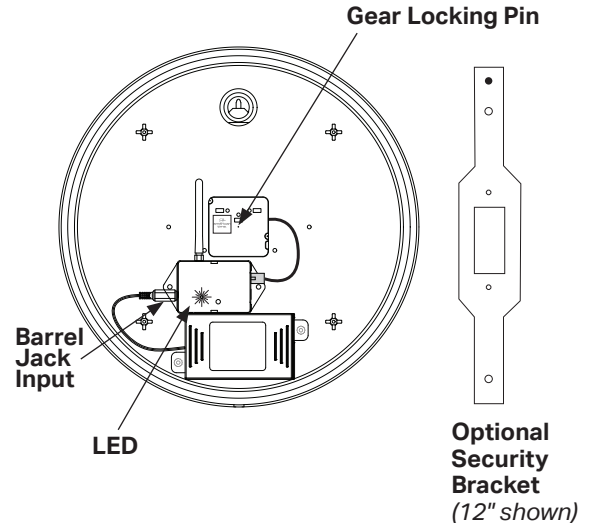

Wireless Analog AC Clocks

Before installation, ensure the gear locking pin (located in the center on the back of the clock) has been removed from the movement.

1. Connect clocks to AC power with cord or Molex kit and confirm green LED is lit after power-up.
 2. The LED on the back of the clock will turn red for 1 second then briefly flash orange (1-15 flashes) indicating the receive frequency on power up. Within 30 seconds of power up the LED will flash red or green. Red indicates the receiver is looking for the signal and green indicates the signal has been received. When the movement starts to correct, the LED will turn green.
- **Note:** If the LED does not flash within 30 seconds, press the reset button on the clock receiver. The LED should begin flashing within 30 seconds.

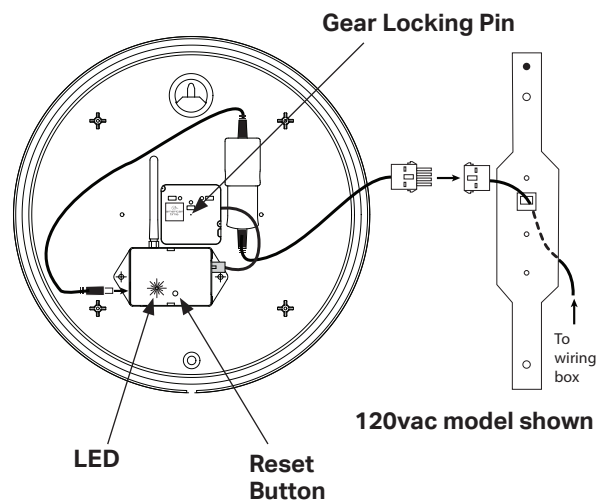

Wireless Analog AC Clocks continued on following page.

Wireless Analog Clock Installation

3. Within 2 minutes after power-up, correction should begin and the clock hands should advance to the correct time. If clocks do not synchronize within 20 minutes of power-up, see **Note** in step 2.
4. Hang the clock using the keyhole hanger on the back of the clock or the security bracket.
5. Continue clock installation. Follow steps 1-4 for the remainder of your clocks. You may skip step 3 and confirm clock synchronization after some or all clocks have been hung.
 - **Note:** Clocks will only attempt to sync to the System Controller at approximately 2 (am and pm) and 8 (am & pm) as displayed on the clocks and after initial power-up or reset.

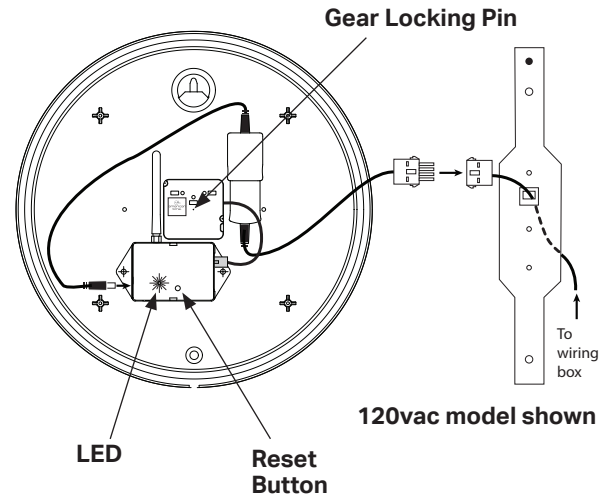

Headway Movement for Analog Clocks

Sync Button: This button is used to sync the clock to the master controller. The master controller must be out of Quiet Mode in order to perform this function. Reference Appendix J in the Installation Manual for more details on Quiet Mode.

Home Button: This button is used to return the clock hands to the 12:00 or Home position. Can be used to verify if the hands are set in the right position.

Reset Button: This button is used to sync the clock to the master controller when the clock is in the Home position. The master controller must be out of Quiet Mode in order to perform this function. Reference Appendix J in the Installation Manual for more details on Quiet Mode.

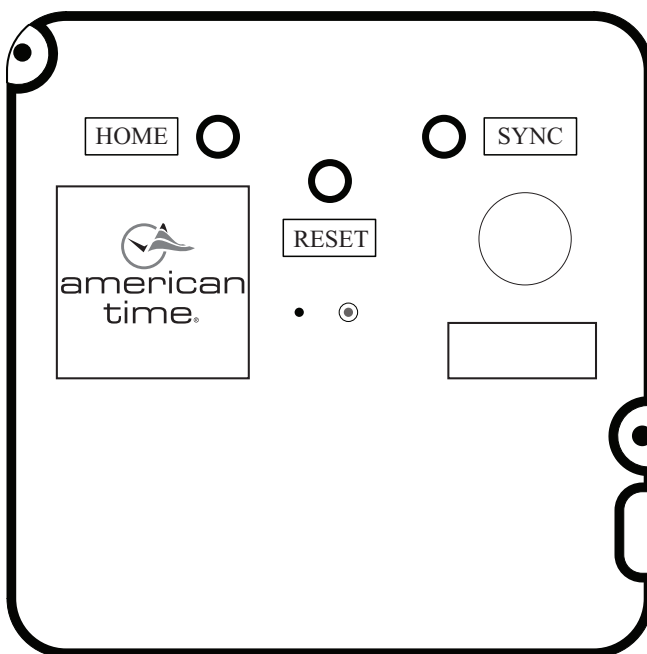

Digital Single Display Surface Mounting

CAUTION: Risk of Electrical Shock - Disconnect and lock out power to the electrical box before installing or servicing the clock.

1. Remove the hanger from the clock by pushing the bracket down and pivoting the studs out of the backplate.
2. Mount the hanger on the wall using the bracket holes, either directly to the wall or to a single or double gang box.
3. For 110v 3-prong corded clock, run the cord through either cutout on the top or bottom of the clock and plug into a grounded outlet.
4. For clocks using Molex connections, make electrical connections (black to hot, white to neutral and green to ground) for the Molex cable (not wired to the clock) to a non-switched electrical circuit wiring using UL approved wire nuts. Route field wiring away from sharp projections and corners.
5. Join the wall and clock Molex together.
6. Seat the bracket spring in the channel on the bottom rail of the clock. Press down and pivot the hanger studs into the holes on the backplate, then release.
7. Remove plastic protector from display face.
8. Apply power to the circuit and confirm correct operation.

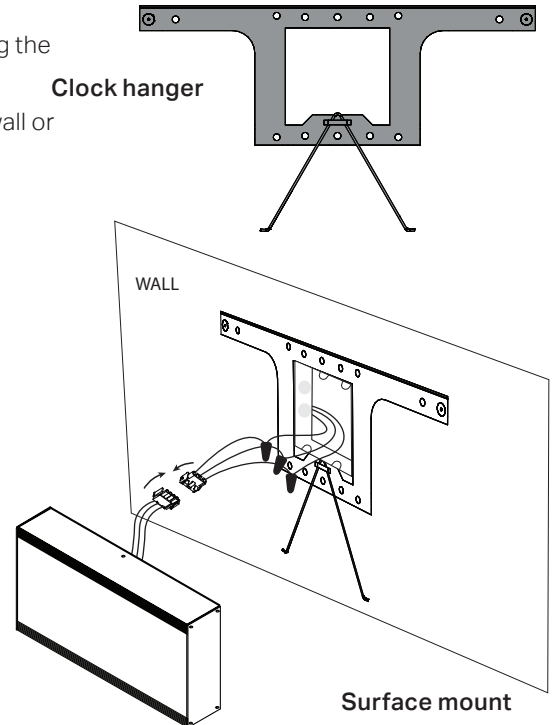

Digital Single Display Flush Mounting

The flush-mount digital clock is designed to be mounted into a wall cavity, similar to a single or double gang box. Ensure that installation conforms to the National Electrical Code and local wiring codes.

- **Note:** If installing the clock to be used with a Timer Control Station, the clock and TCS must be no more than 30ft apart.

1. Remove the four sheet metal screws (A) that hold the cover assembly (B) and enclosure base (C) together. Be sure to keep the sheet metal screws for reassembly.
2. Mount the enclosure base (C) into the wall by attaching the side of the back box to a stud. Opening is 12.5" x 7.4" x 3.629".

If you are installing a Timer Control Station, proceed to Step 3. To finish clock installation without a Timer Control Station, proceed to Step 6.

3. Pull the wiring from the Timer Control Station (D) through the knockouts in the enclosure.
4. Connect the Timer Control Station wiring to the provided terminal plugs. See wiring detail in the ATSTCS documentation for detailed wiring information.
5. Connect the terminal plug(s) to the terminal blocks on the clock as described in the ATSTCS documentation.
6. Connect line power and correction line wiring (E) to the Molex connector (G). White to neutral, black to positive/hot, and green to ground.
7. Join the Molex connectors (G & H) together, placing excess wiring and Molex connectors into the gang box.

Chassis ground **MUST** be connected to conduit/Earth ground to provide proper protection from electric shock.

CAUTION: Electric Shock Hazard! When making installation, route field wiring away from sharp projections, corners, and internal components.

8. Re-attach the cover assembly (B) to the enclosure base (C) using the sheet metal screws (A) removed in Step 1.

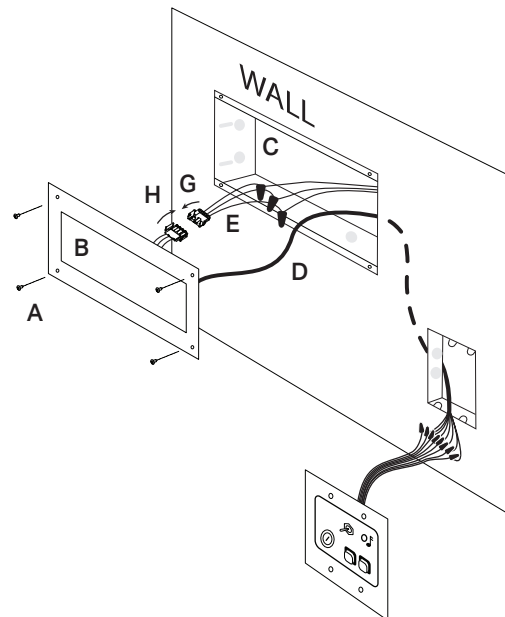

Digital 2-Sided Display - Ceiling or Wall Mount

CAUTION: Risk of Electrical Shock - Disconnect and lock out power to the electrical box before installing or servicing the clock.

1. Make electrical connections (black to hot, white to neutral and green to ground) for the Molex cable (not wired to the clock) to non-switched electrical circuit wiring using UL approved wire nuts. Route field wiring away from sharp projections and corners.
2. Join the wall/ceiling and clock Molex together.
3. Mount the clock to the ceiling (4" box) or wall (single or double gang box).
4. Remove plastic protector from display face.
5. Apply power to the circuit and confirm correct operation.

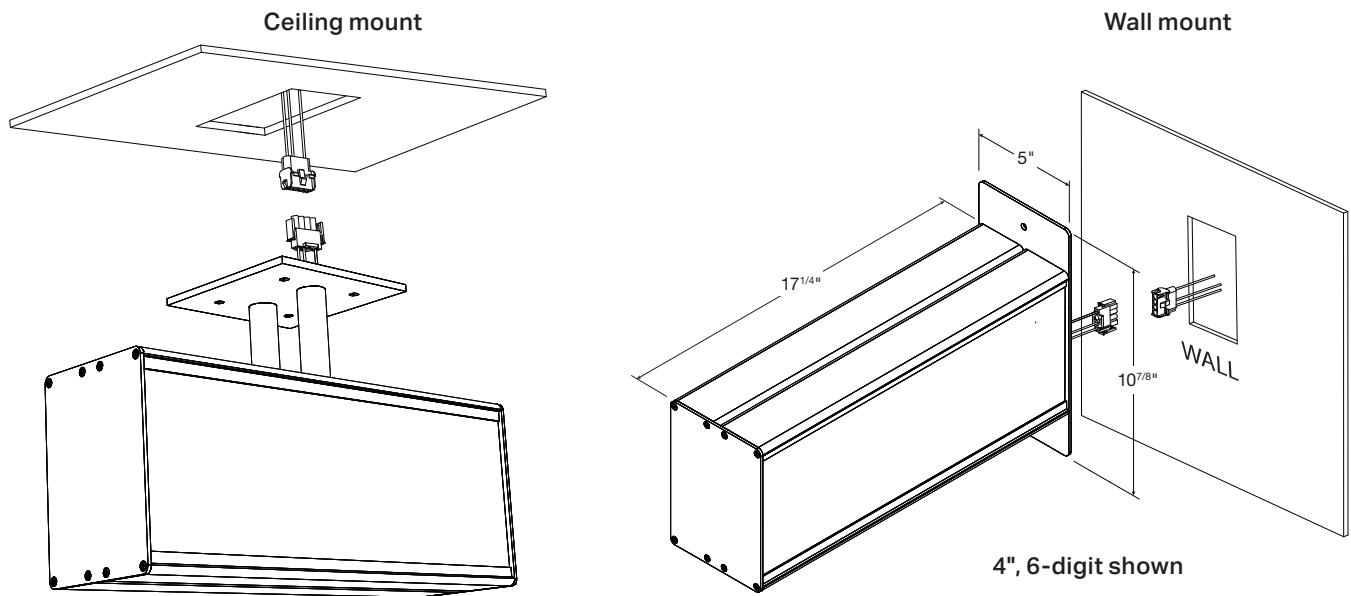

Power Up

After power is applied to the digital clock, the firmware version number will appear for a few seconds, followed by all digits illuminated. It will then scroll a digit pattern while it looks for the correct time from the SiteSync IQ system controller. Once the receiver inside the clock gets a signal, the clock will begin keeping time. At first startup, the clock may display a time such as 1:00:00 until it receives the first time update from the SiteSync IQ system controller. This should only take a few seconds, after which the correct time from the SiteSync IQ system controller should appear.

Setting Time

Setting of the time is not needed for the digital clock or timer control station. The time information is automatically updated by the SiteSync IQ system controller. The 12- or 24-hour mode option can be configured by the display settings of the system controller, or by the push buttons on top of the clock.

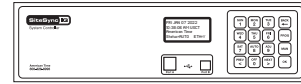

If you have any of these problems, follow the appropriate steps:

- System controller appears off (LCD dark) when power is connected:
 - Disconnect power and remove top cover. Check fuse and replace if necessary.
- Wireless analog clocks not synchronized with system controller:
 - Verify the System Controller is transmitting. **TX** should be displayed on the LCD screen every 30 seconds, unless the System Controller is in Quiet Mode. Reference Appendix J for more details on Quiet Mode.
 - If your system has an external transmitter, check all cable connections (also check the data cable and pins for damage) and verify the PTT and DATA LEDs are lit on the external transmitter when **TX** is displayed on the System Controller
- System Controller is not transmitting:
 - If **TX** is not being displayed every 30 seconds:
 - Ensure system Controller is not in Quiet Mode. Reference Appendix J for more details on Quiet Mode.
 - Ensure **TX** window is off (Reference "Settings and Configuration" Step 2).
 - Press **SUN 1** **WED 4** **THU 5** and ensure **TX ON** is displayed. IF **TX OFF** is displayed, press **SUN 1** **WED 4** **THU 5** again.
 - If your system has the campus antenna kit, it may have been hit by lightning, even if there are no visible signs of damage to the system equipment. If this is the case, the signal coverage will be greatly reduced and the system clocks may not be able to receive the signals from the transmitter. The lightning arrester (item D shown in "Campus Transmitting Antenna Installation" section) contains a gas discharge tube which is designed to protect the transmitter and attached equipment from lightning damage. There is no visible way to determine if the gas discharge tube is good or not. The only way to check the gas tube is to use an Ohmmeter. If the unit is bad, the Ohmmeter will show a "Short". If the unit is in good condition, it will show a high resistance. A replacement discharge tube is available from the manufacturer, or the entire lightning arrester (ATS part #H003491) can be replaced by contacting American Time.
- Power has been reset, **Press OK** is displayed on the LCD screen:
 - Verify that the power source is stable
 - Press **OK** if there was a power outage, if power is not supplied by a switchable plug, or if unit was unplugged
 - Determine source of power loss
- Unit Crashed. **Press OK** is displayed on the LCD screen:
 - The system controller will automatically reset and resume normal operation if the unit crashes.
 - Diagnostic information is saved to the unit for troubleshooting.
 - If this occurs frequently, please update to the newest firmware, as the issue may have already been resolved.
- Incorrect time is displayed by system controller after loss of power:
 - Backup battery may be dead. Check for "Low Battery Voltage" message when time is displayed in small text (see Display Settings section). If this message is displayed, replace battery with new CR2032 or equivalent 3v lithium battery. Install battery with + side up, as shown below.
- Power outage during Daylight Saving Time correction:
 - If there is a power outage during the correction period for Daylight Saving Time, the secondary clocks might not correct. In this case, the clocks can be reset manually (see Clock Troubleshooting) or they will automatically reset during their next reception attempt after the power is restored.
- Signal circuits not responding to programmed events:
 - Refer to Wired Signal Circuit Troubleshooting Guide.
- Unable to synchronize with Ethernet Time Source:
 - Refer to the Ethernet Troubleshooting Guide.
- Unable to synchronize with GPS Time Source:
 - Refer to the GPS Troubleshooting Guide.
- Lost or forgotten User Lock:
 - Contact American Time Technical Support at the number listed below.
- SiteSync IQ System Controller locks up or display goes blank:
 - Use a pen, small screwdriver or paperclip to press the reset button (See diagram in Appendix G). or
 - Remove power from the unit by switching the Power Input switch off, wait 5 seconds, then turn the unit back on.

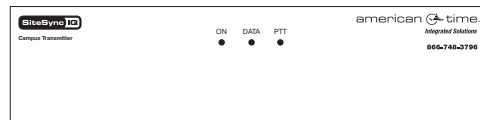

LED colors:

ON=Red

DATA=Green

PTT=Yellow

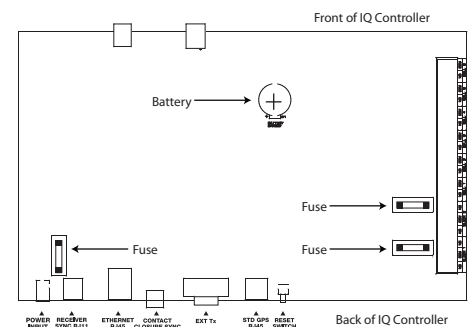



If you have trouble synchronizing to GPS, follow these troubleshooting steps:

1. If GPS receiving antenna has been connected to the SiteSync IQ System Controller for less than 25 minutes, the GPS time signal may be inaccurate. Allow more time. If still not synchronizing follow these steps:

- Press: **PROG** **THU 5**, to check the GPS signal status.

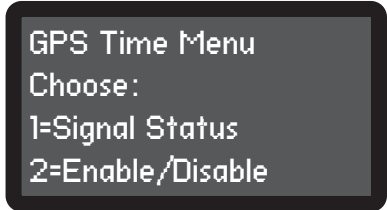

- Press: **SUN 1**, to check signal status.

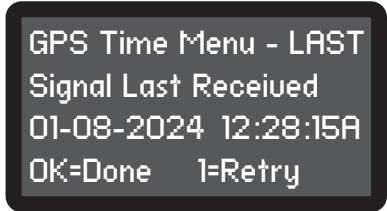

- If no signal was received, continue to Step 2.



- If signal was received, press **OK** to view number of connected satellites.
Press **OK** **BACK** **BACK** to return to the Main screen.

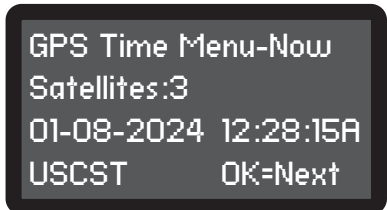

■ **Note:** If 0 satellites are connected, continue the troubleshooting steps.

2. Check the GPS cable connections between the System Controller and GPS antenna. Replace any damaged cables and verify the connectors are securely locked together. If you are using extension cables, try temporarily moving the system controller closer to the GPS antenna and connect without the extension cables (if possible).

3. If no signal has been received after checking the status and configuration, move the GPS antenna to a better location and follow the installation and configuration steps again.

4. Ensure the GPS update function is enabled:

- Press **PROG** **THU 5** **MON 2**;

- Enter User Lock, then press **OK**;

Display should show:

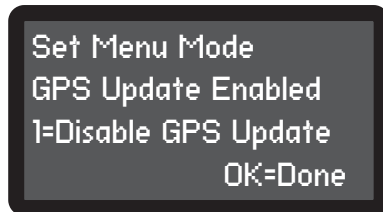

If not, press **SUN 1** then **OK**.

5. Inspect the GPS antenna for damage. Look for signs of lightning strikes or falling debris.

6. Look for obstructions to the antenna's view of the sky and remove them if possible (example: tree branches). Clear any snow or ice off the antenna and surrounding area.

7. If the GPS antenna is installed behind a Low-E glass window or skylight, try another location or replace the glass if possible.

If the problem cannot be resolved after following these steps, please call Technical Support at American Time at **800-328-8996**.

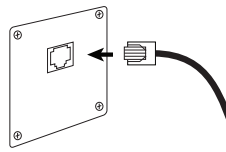

If you have trouble connecting the SiteSync IQ System Controller via Ethernet, follow these troubleshooting steps:

1. Check the Ethernet cable connection to the SiteSync IQ System Controller. Make sure the patch cable is securely connected to the Ethernet RJ-45 port and that it is not damaged. Have the cable tested or connect a computer or another Ethernet device to this cable to confirm proper connection.
2. Ensure that the Ethernet is enabled. From the main screen:
 - Press: **PROG** **AUTO 8** **MON 2**, enter User Lock, and press **OK**. Press **MON 2** to enter the Client menu.
 - If Ethernet is Disabled, press **SUN 1** to enable and press **OK**.

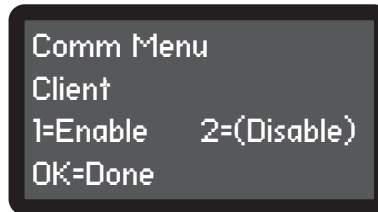
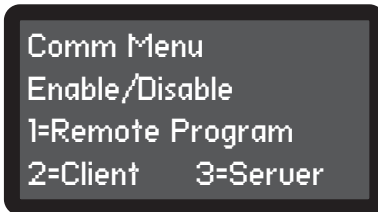

Verify the packet counts for RX and TX are greater than 0. Press **SUN 1** **OK** **NEXT >** from the Comm Menu.

- If greater than 0, press **OK** **BACK ←** **BACK ←** to return to the Main screen. If packet counts are 0, continue with troubleshooting steps.

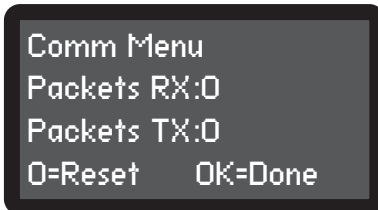

3. Initiate Sync Now:

- Press: **PROG** **SUN 1** to Set Menu Mode.
- Enter User Lock and press **OK**.
- Press: **ADJ 9** to sync the System Controller with Ethernet. Press **>** until Ethernet option is chosen.
- Press **AUTO 8** to sync with Ethernet.

Confirm all Network settings (see "Ethernet Installation" section of this manual). Make sure the SiteSync IQ System Controller is configured properly.

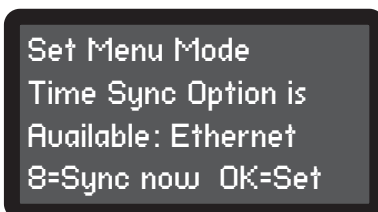

5. Change the Time Server IP address to a different timeserver among those listed in Appendix A. Perhaps the timeserver that the system controller is attempting to communicate with is down or not responding quickly enough due to network traffic, etc.
6. Press: **PROG** **AUTO 8** **THU 5** to see the current IP address. Confirm the IP address is valid and no other device or computer on the network is using the same IP address. The Network Administrator should be able to resolve any conflicts.
7. Ensure that the Network has port 123 open for SNTP or port 13 open for Daytime Protocol.
8. Ping the IP address of the unit from another computer to see if it is responding. Check with your Network Administrator if you do not know how to do this.
9. Test the time server by attempting to get a time stamp from another computer. Check with your Network Administrator if you do not know how to do this.

If the problem cannot be resolved after following these steps, please call Technical Support at American Time at **800-328-8996**.

If you have trouble connecting the SiteSync IQ System Controller to the Remote Connect software, follow these troubleshooting steps:

1. Check the Ethernet cable connection to the SiteSync IQ System Controller. Make sure the patch cable is securely connected to the Ethernet RJ-45 port and that it is not damaged. Have the cable tested or connect a computer or another Ethernet device to this cable to confirm proper connection.

2. Ensure that the Remote Programming is enabled. From the main screen:

- Press: **PROG** **AUTO 8** **MON 2**, enter User Lock, and press **OK**. Press 1 to enter the Remote Prog menu.

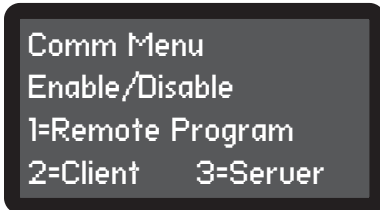

- If Remote Programming is Disabled, press **SUN 1** to enable and press **OK**.

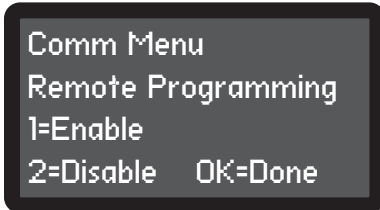

3. Confirm all Network settings (see "Ethernet Installation" section of this manual). Make sure the SiteSync IQ System Controller is configured properly.

4. Press: **PROG** **AUTO 8** **THU 5** to see the current IP address. Confirm the IP address is valid and no other device or computer on the network is using the same IP address. The Network Administrator should be able to resolve any conflicts.

5. Ensure the Network has Port 80 open.

6. Ping the IP address of the unit from another computer to see if it is responding. Check with your Network Administrator if you do not know how to do this.

7. If the Sitesync IQ system controller is configured in DHCP mode and you are not able to connect to the Remote Connect interface, ensure that the device is on a network that will serve DHCP addresses. If no DHCP server is present or fails to receive an address, the SiteSync IQ system controller will default to 192.168.10.10. Try connecting to the SiteSync IQ system controller by typing in its IP address in the address field of the browser in this format: `http://xxx.xxx.xxx.xxx/` or Host Name: `http://ssiqxxxxxx/` and click Enter.

■ **Note:** The connecting computers IP address must be on the same Subnet.

Example 1 - IP address



Example 2 - Host Name



If the problem cannot be resolved after following these steps, please call Technical Support at American Time at **800-328-8996**.

If you have trouble connecting the SiteSync IQ System Controller via Contact Closure, follow these troubleshooting steps:

1. Verify that contact closure sync is enabled:
 - a. System Controllers with {GPS + Ethernet} do not have contact closure input capability.
 - See the table on Page 5 and refer to your model number.
 - b. Confirm contact closure is enabled in the Comm Menu by pressing **PROG** **ADJ 9** User Lock **OK**.
 - See Page 19 for more information.
2. Check the Contact Closure connection to the IQ System Controller. Make sure the two wires are securely connected.
3. Ensure that the sync time is correct. See instruction on Page 20 for setting the sync time on the SiteSync IQ System Controller. Refer to the instructions provided by the manufacturer of any connected device to set its sync time.
4. Test contact closure wiring by removing the two wires from the output device and shorting them together. If this does not result in the receiving device going to the specified sync time, try removing the two wires from the receiving device and using a jumper wire to short the terminals.

If the problem cannot be resolved after following these steps, please call Technical Support at American Time at **800-328-8996**.

Troubleshooting Wireless Sync

If you have trouble synchronizing the SiteSync IQ System Controller via the Wireless Sync Option, follow these troubleshooting steps:

1. Verify that the model number of your SiteSync IQ System Controller supports wireless sync. Refer to the table on Page 5.
2. Ensure reception of time signal from the transmitting system controller using a pager or wireless clock.
 - **Note:** If the transmitting system controller is in Quiet Mode, press 3-5-7 to temporarily disable Quiet Mode.
3. Check the LED status on the receiver:
 - a. Upon power-up the receiver should flash green.
 - b. Upon receiving a valid time signal, it will flash red for about 1 second.
 - c. If the LED doesn't flash, verify that the RJ-11 connections are secure.
4. Initiate Sync Now:
 - Press: **PROG** **SUN 1**, to Set Menu Mode.
 - Enter User Lock and press **OK**.

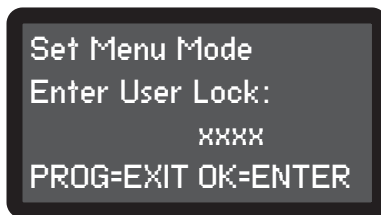

- Press: **ADJ 9** to sync the receiving System Controller. Press **NEXT >** until WLS option is chosen.

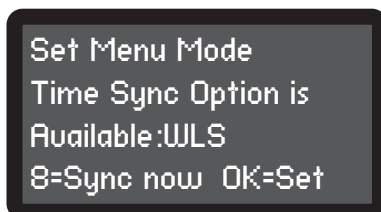

- Press **AUTO 8** to sync time.

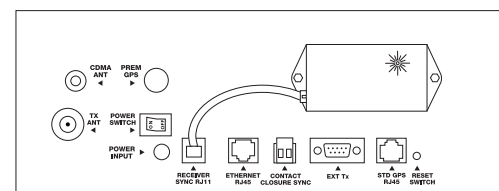

If the problem cannot be resolved after following these steps, please call Technical Support at American Time at **800-328-8996**.

If you have trouble operating wired clock circuits, follow these troubleshooting steps:

1. Ensure you have the clock code configured in your system controller:
 - a. Press: **PROG** **SAT 7** to enter the Config Menu
 - b. Enter your Service Lock if necessary.
 - c. Press **WED 4** to enter the Clock Code select screen and verify that it is correct.

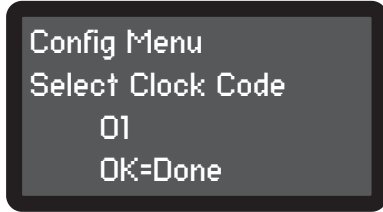

2. If the system controller time was recently changed, allow up to 24 hours for secondary clocks to re-synchronize to the system controller.
3. Ensure there is sufficient voltage across each secondary clock.
4. If fewer than 25 AllSync secondary clocks are connected to the system controller, the secondary clocks might not recognize the correction from the system controller. Connect all intended clocks and allow time for normal system controller correction. If secondary clocks still have not corrected, you may need additional hardware. Contact American Time Technical support for information on adding a Resistor Pack (Part #H001941) to your system.

If the problem cannot be resolved after following these steps, please call Technical Support at 800-328-8996.

If you have trouble operating wired signal circuits, follow these troubleshooting steps:

1. Signal circuits not responding to programmed events:
 - a. Make certain that the system controller status is set to AUTO:
 - Press **AUTO 8**, enter User Lock, if applicable, and press **OK**.
 - b. Confirm that signal circuits are enabled. From the View Circuits screen:
 - Press **TUE 3** to enter the Enable Circuits screen to view or change the control status of individual circuits.

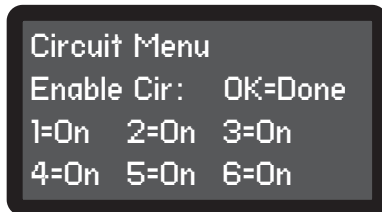

- c. Confirm that signal circuits and events programmed to control them are assigned to the same schedule.
 - d. Check for correct voltage at signal relay contacts. The COM (common) terminals should measure full voltage all the time. The NO (normally open) terminals should have power only when the circuit is activated.
2. Signal circuit(s) On when they should be Off:
 - a. Press **MAN**, enter User Lock, if applicable, and press **OK**. Then choose circuit(s) to activate/deactivate.
 - b. If the circuit does not toggle On or Off, check for stray voltage on the signal relay normally open contacts.
 - **Note:** You can try disabling the surge protection circuitry by switching it off (see diagram). These switches are located inside the wiring compartment. Remove power to the System Controller and signal circuit lines before removing cover to access wiring.
 - c. Verify the LED for the circuit is Off (see diagram).
3. Signal circuits not responding at all:
 - a. Carefully open the top cover of the SiteSync IQ system controller by removing the screws on each side of the unit.
 - b. Press the **MAN** key, enter User Lock, if applicable, then press **OK**.
 - c. Choose the circuit(s) you wish to test and press the **MAN** key to trigger the applicable relay(s).
 - d. Observe the LED(s) next to the circuit relays being tested. If they light up when the circuit is being triggered, verify the operation of the relay by measuring the voltage on the relay terminals. The NO terminal should have power. If they don't light up, verify the circuits are enabled (see Step 1b above).

If the problem cannot be resolved after following these steps, please call Technical Support at 800-328-8996.

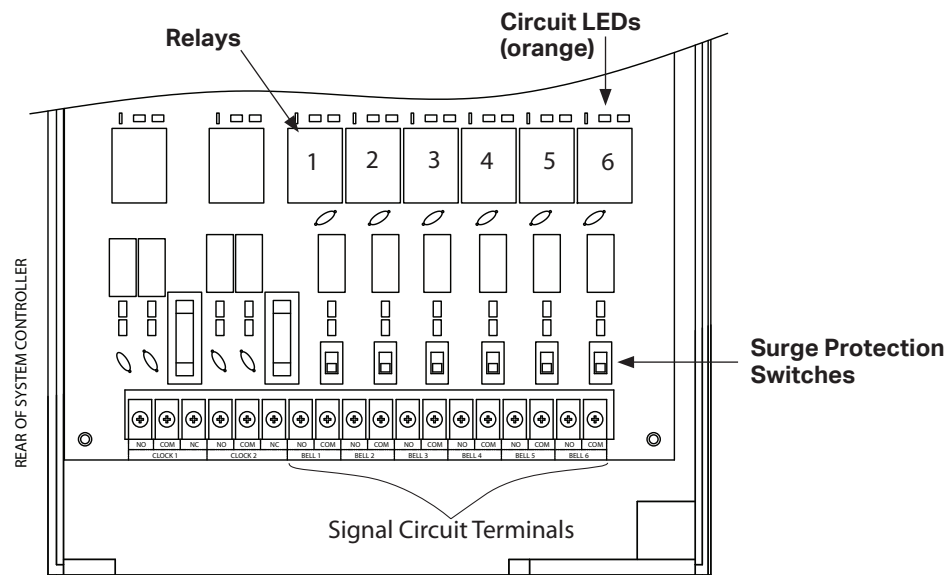



Wireless Analog Clock Troubleshooting

Quiet Mode – With Quiet Mode enabled, clocks may not correct until the hours of 12AM-6AM. If clock corrections are needed during the day, Quiet Mode can be disabled by pressing 3-5-7 on the system controller (reference Appendix K).

If **ALL** clocks are not synchronizing:

1. **Review System Controller troubleshooting.** (Reference “Troubleshooting System Controller” section of SiteSync IQ Wireless Installation Manual)
 - a. A TX symbol will appear in the lower right hand corner of the system controller display every 30 seconds if it is set up properly. However, in Quiet Mode the TX will not appear every 30 seconds.
2. Contact American Time Technical Support at **800-328-8996**.

If only **SOME** clocks are not synchronizing, continue with the trouble shooting steps.

1. **If using battery clocks, confirm the battery voltage and polarity:**
 - a. Using a multi-meter, verify the voltage is between 1.45-1.80V at the battery booster. Clocks will not function properly below 1.45V.
 - b. Polarity of the batteries inside battery pack after installation.
 - c. Barrel jack plug of battery pack is connected to the wireless Receiver module.
2. **If using AC clocks, confirm the power for the clocks:**
 - a. Barrel connector at the clock is connected and secure.
 - b. Green LED is lit on the receiver.
3. **Confirm signal by resetting clock at location:**

Battery Clocks

- a. Disconnect barrel jack plug from wireless Receiver module
- b. Reconnect barrel jack plug after waiting 5 seconds.
- c. Watch for LED to flash, will flash red for approximately one minute after power is applied until a valid signal is received. LED will flash green once signal is received.

AC Clocks

- a. Press and release the reset button on the back of the receiver with power supplied.
 - b. Watch for LED to flash, will flash red for approximately one minute after power is applied until a valid signal is received. LED will flash green once signal is received.
4. **Clocks that Slow Tick** – Normal startup, the clock will tick once every 2-3 seconds. Wait 5 minutes for clock to get signal.
 5. **Out of Signal Range** – If the clock has not received a signal within 5 minutes the clock will run to between 2:00-2:30 and run normally. Move clock within a known signal area and re-try, the clock may be too far from the system controller or in an interference area.
 6. **Hand Obstructions** – If hands are touching each other, the dial or the crystal the clock may become off time. (Reference Instruction Sheet 2080 to rehome and reposition clock hands)
 7. **Hands Physically Moved** – Clock hands cannot be physically moved, they are set at the factory to a “Home” position. If the hands are physically rotated, the home position will be off resulting in the time being off. (Reference Instruction Sheet 2080 to rehome and reposition clock hands)
 8. **Hours Off** – Remove the label on the movement and verify the rotary switch is set to MT. Switch must be set to MT no matter what time zone the clock is located.
 - **Note:** This step may not apply if clocks are received after 4/3/12.
 9. **Minutes Off** – The clock may have been jarred during shipment or dropped resulting in the hands being a few minutes off. (Reference Instruction Sheet 2080 to rehome and reposition clock hands)
 - **Note:** The clock(s) will only attempt to sync to the SiteSync IQ Controller at approximately 2am/pm and 8am/pm as displayed on the clock(s) or after the clock(s) are initially powered up.

If problems cannot be resolved after following these steps, please call Technical Support at American Time at 800-328-8996.

Wireless Digital Clock Troubleshooting

1. If all clocks are not synchronizing:
 - a. Review System Controller troubleshooting.
 - b. Contact American Time Technical Support at 800-328-8996.
2. If only some clocks are not synchronizing, continue with the troubleshooting steps.
3. Confirm signal – Reference pictures below.
 - a. Wait until the top of the minute and verify time synchronizes to the System Controller.
 - **Note:** After the system controller has been operating for 24 hours, it will enter Quiet Mode. Pressing 3-5-7 on the keypad will disable Quiet Mode for 6 hours. Reference Appendix J for more details on Quiet Mode.
4. Move the clock closer to the transmitter or to an area where another clock is working (if poor signal coverage is suspected) and reset the clock time per digital clock troubleshooting (Step 3 above).

If the problem cannot be resolved after following these steps, please call Technical Support at American Time at 800-328-8996.

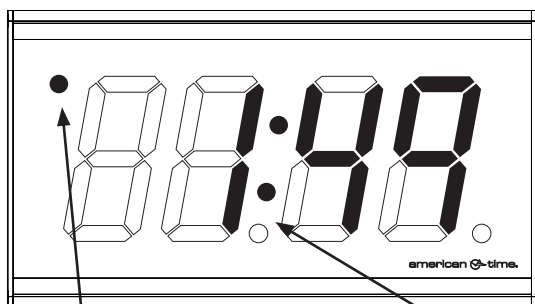

PM Indicator

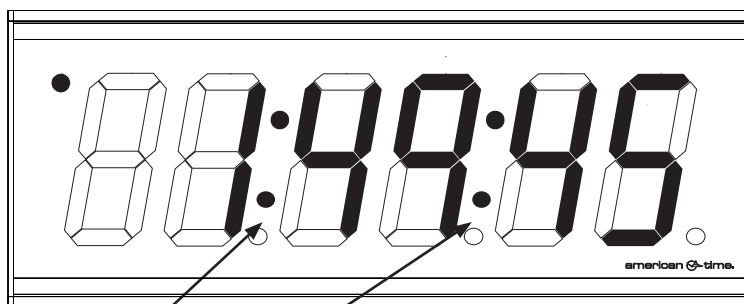

Colons: Flash when the wireless time update signal has not been received.

NIST Internet Time Servers

Using the SiteSync IQ System Controller as a Time Server

The SiteSync IQ System Controller with Ethernet option can be used as a time server supporting the SNTP and Daytime protocols and can be used to synchronize computers or other devices via the Ethernet. A typical configuration would be a SiteSync IQ System Controller with GPS and Ethernet options, where GPS is used as the time source for the IQ System Controller and Ethernet is used to sync the time on a network server or various workgroup computers.

To set up your computer or other device to synchronize to the IQ System Controller, simply enter the IP address of the IQ System Controller as the time server address for the computer or device.

In Windows XP:

1. Right-click your clock and then click Adjust Date/Time.
2. Click the Internet Time tab, click the Server down arrow, and then enter the IP address of the SiteSync IQ system controller you wish to synchronize this computer to (example: 192.168.1.200).
3. Click Update Now. Windows XP will connect to the IQ System Controller and set the computer's clock.

In Windows 7:

1. Right-click your clock and then click Adjust Date/Time.
2. Click the Internet Time tab, and then click Change Settings.
3. Check Synchronize with an Internet time server, enter the IP address of the IQ System Controller you wish to synchronize this computer to (example: 192.168.1.200), and then click OK.

■ Important Notes:

- Setting up your computer to synchronize to the IQ System Controller via Ethernet does not account for time zone and Daylight Saving Time settings, which must be properly set on the computer (they are not transferred via Ethernet).
 - The computer or other device being synchronized to the IQ System Controller must be on the same network as the SiteSync IQ system controller, or have access to it through a firewall (port 123 open for SNTP and port 13 open for Daytime Protocol).
 - If your computer is on a domain, it is set up to get the time from the domain controller and you will not be able to perform the above tasks. Domain controllers using the Windows Time Service can be set up by your network administrator to synchronize directly to time servers on the Internet or to the IQ System Controller. Contact American Time Technical Support at **800-328-8996** with any questions.
- **Note:** Please reference <https://tf.nist.gov/tf-cgi/servers.cgi> for the latest NIST Internet Time servers list, which includes the status of each server.

Appendix B: Supported Time Zones

Time Zone Code	Description	Hours Difference from UTC (Winter)	Hours Difference from UTC (Summer)	Automatic Daylight Saving Time Adjustment
00	LMT (Local Mean Time) - based on longitude	CALCULATED	CALCULATED	CONFIG
01	USA Alaska	-9	-8	YES
02	USA Aleutian (HAST/HADT)	-10	-9	YES
03	USA Arizona	-7	-7	NO
04	USA Atlantic / Puerto Rico (AST)	-4	-4	NO
05	USA Central (CST/CDT)	-6	-5	YES
06	USA Chamorro (chST)	+10	+10	NO
07	USA Eastern (EST/EDT)	-5	-4	YES
08	USA Hawaii (HST)	-10	-10	NO
09	USA Indiana East	-5	-5	NO
10	USA Mountain (MST/MDT)	-7	-6	YES
11	USA Pacific (PST/PDT)	-8	-7	YES
12	USA Midway Island / Samoa (SST)	-11	-11	NO
13	USA Wake Islands (WAKT)	+11	+11	NO
14	UTC+0	+0	+0	CONFIG
15	UTC+1	+1	+1	CONFIG
16	UTC+2	+2	+2	CONFIG
17	UTC+3	+3	+3	CONFIG
18	UTC+4	+4	+4	CONFIG
19	UTC+5	+5	+5	CONFIG
20	UTC+6	+6	+6	CONFIG
21	UTC+7	+7	+7	CONFIG
22	UTC+8	+8	+8	CONFIG
23	UTC+9	+9	+9	CONFIG
24	UTC+10	+10	+10	CONFIG
25	UTC+11	+11	+11	CONFIG
26	UTC+12	+12	+12	CONFIG
27	UTC+13	+13	+13	CONFIG
28	UTC-1	-1	-1	CONFIG
29	UTC-2	-2	-2	CONFIG
30	UTC-3	-3	-3	CONFIG
31	UTC-4	-4	-4	CONFIG
32	UTC-5	-5	-5	CONFIG
33	UTC-6	-6	-6	CONFIG
34	UTC-7	-7	-7	CONFIG
35	UTC-8	-8	-8	CONFIG
36	UTC-9	-9	-9	CONFIG
37	UTC-10	-10	-10	CONFIG
38	UTC-11	-11	-11	CONFIG
39	UTC-12	-12	-12	CONFIG
99	Custom Time Zone	CONFIG	CONFIG	CONFIG

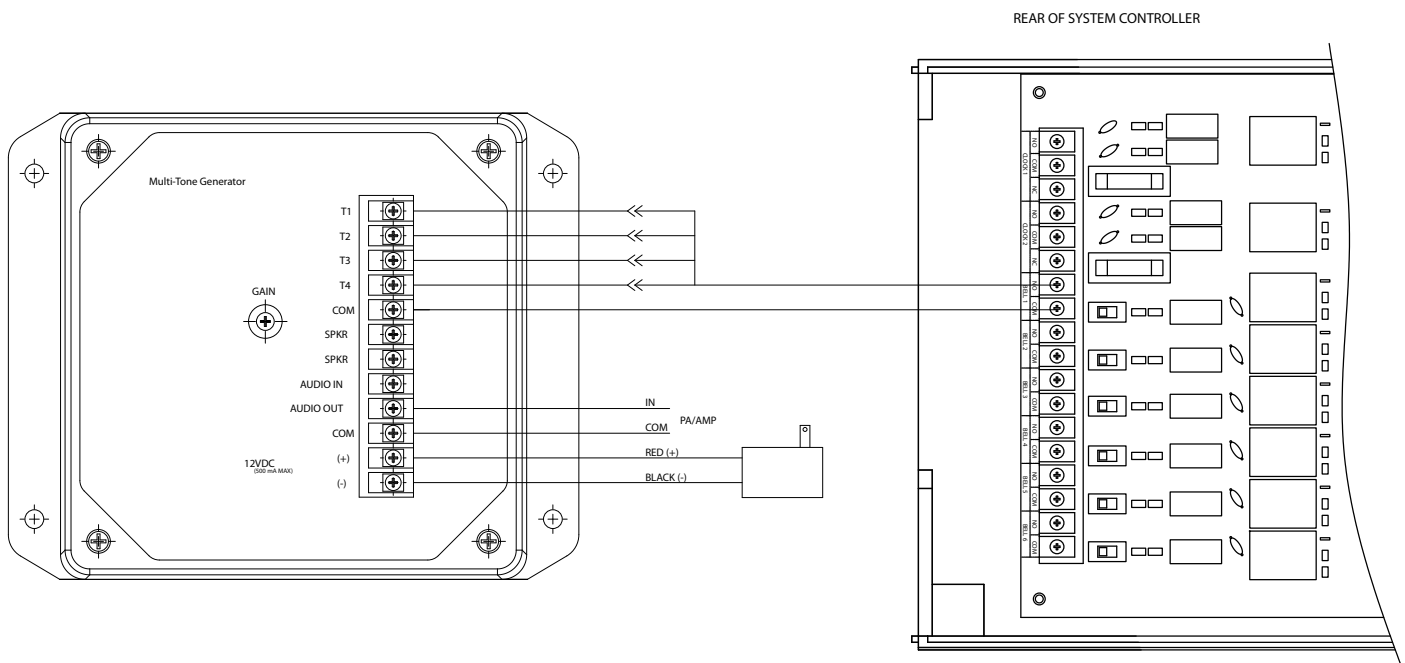

Example: Programming Recurring Events

To program a new event in Schedule 2 that turns on signal circuits for 5 seconds starting at 8:55 AM every weekday Monday-Friday, press:

- Step 1:
- Step 2:
- Step 3: Enter User Lock (unless User Lock is disabled)
- Step 4: (unless User Lock is disabled)
- Step 5: for Schedule/Event
- Step 6: for Schedule 2
- Step 7:
- Step 8: if necessary to display New Event
- Step 9: to deselect Saturday and Sunday
- Step 10: to accept day selection
- Step 11: for time
- Step 12: if necessary to select AM
- Step 13: to accept time
- Step 14: for event duration
- Step 15: to accept duration
- Step 16: to accept - Min Countdown Duration
- Step 17: to accept Message Number 0
- Step 18: to save event

At this point, to program a new event for the same schedule, days and duration, simply Press and enter the new start time and press . To stop programming similar events press . Press to exit Event Menu. Press again to exit Program Menu if programming is complete.

Example: Reviewing and Editing Events by Schedule

To change only the duration of Event 24 in Schedule 2 to 6 seconds, press:

- Step 1:
- Step 2:
- Step 3: Enter User Lock (unless User Lock is disabled)
- Step 4: (unless User Lock is disabled)
- Step 5: for Schedule/Event
- Step 6: for Schedule 2
- Step 7:
- Step 8: for event number
- Step 9: to jump to event 24
- Step 10: to show event weekdays
- Step 11: to accept day selection
- Step 12: to accept time
- Step 13: for event duration
- Step 14: to accept duration
- Step 15: to accept 0 Min Countdown Duration
- Step 16: to accept Message Number 0
- Step 17: to save event

Press to exit Event Menu. Press again to exit Program Menu if review/edit is complete.

Example: Programming Signal Circuits

To assign Signal Circuit 1 to Schedule 12 with a default duration of 5 seconds, and Signal Circuit 4 to Schedule 6 with a default duration of 8 seconds, press:

- Step 1: **PROG**
- Step 2: **TUE 3**
- Step 3: Enter User Lock (unless User Lock is disabled)
- Step 4: **OK** (unless User Lock is disabled)
- Step 5: **SUN 1** for Schedule
- Step 6: **SUN 1** to select Circuit 1
- Step 7: **SUN 1** **MON 2** to assign Circuit 1 to Schedule 2
- Step 8: **OK**
- Step 9: **MON 2** to select Duration
- Step 10: **THU 5** to set Circuit 1 default duration to 5 seconds
- Step 11: **SUN 1** to select Schedule
- Step 12: **WED 4** to select Circuit 4
- Step 13: **OFF 0** **FRI 6** to assign Circuit 4 to Schedule 6
- Step 14: **OK**
- Step 15: **MON 2** to select Duration
- Step 16: **AUTO 8** to set Circuit 4 default duration to 8 seconds

Press **PROG** to exit Signal Circuit Menu. Press **BACK** again to exit Program Menu if programming is complete.

Example: Programming Special Events

To program a new special event in Schedule 2 that turns on signal circuits for 8 seconds starting at 3:45 PM on October 31, 2008, press:

- Step 1: **PROG**
- Step 2: **MON 2**
- Step 3: Enter User Lock (unless User Lock is disabled)
- Step 4: **OK** (unless User Lock is disabled)
- Step 5: **SUN 1** for Schedule/Event
- Step 6: **OFF 0** **MON 2** for Schedule 2
- Step 7: **OK**
- Step 8: **PREV <** if necessary to display New Event
- Step 9: **OK**
- Step 10: **OFF 0** to select Special
- Step 11: **MON 2** **OFF 0** **OFF 0** **AUTO 8** to change year to 2008
- Step 12: **OK** to accept year
- Step 13: **SUN 1** **OFF 0** to change month to October
- Step 14: **OK** to accept month
- Step 15: **SUN 1** to select Set Date
- Step 16: **TUE 3** **SUN 1** to set date
- Step 17: **OK**

Example: Programming Special Events (continued)

- Step 18: to set start time
- Step 19: to select PM
- Step 20:
- Step 21: to set duration
- Step 22:
- Step 23: to accept 0 Min Countdown Duration
- Step 24: to accept Message Number 0
- Step 25: to save event

Press to exit Event Menu. Press again to exit Program Menu if programming is complete.

Example: Switching Assigned Schedules

This example will demonstrate a temporary holiday schedule switch. The current schedule (01) will be switched to Sch 02 on December 23, 2008 at Midnight and then switched back after a period of time.

- Step 1: and enter User Lock (if applicable). Press .
- Step 2: Select a circuit in which the schedule is to change (1-6). For our example, we'll select circuit 1.
- Step 3: Press to change the schedule on circuit 1.
- Step 4: Press .
- Step 5: Use the keys to select a schedule to change to. Only schedules with events programmed will be selectable.
- Step 6: Press .
- Step 7: Enter the year 2008 and press .
- Step 8: Enter the month 12 and press .
- Step 9: Enter the day 23 and press .
- Step 10: Enter the time (hours) 12 and press .
- Step 11: Enter the time (minutes) 00 and press .
- Step 12: Select AM using the keys and press .

This should return you to the replacement schedule screen (Step 4)

To change the schedule back to Sch 01 on January 15, 2009:

- Step 13: Press .
- Step 14: Use the keys to select the original schedule.
- Step 15: Press .
- Step 16: Enter the year 2009 and press .
- Step 17: Enter the month 01 and press .
- Step 18: Enter the day 15 and press .
- Step 19: Enter the time (hours) 12 and press .
- Step 20: Enter the time (minutes) 00 and press .
- Step 21: Select AM using the keys and press .

This should return you to the replacement schedule screen (Step 4).

- Step 22: Press to exit to the main screen.

Appendix E: Checking IQ System Controller Status Information

Example Screens

Turn on the power to the System Controller

Press: to access the Status Menu.

1 Clock Code: From the Status Menu press

This displays the currently configured clock code.

- Press to exit.

2 Last Time Set: From the Status Menu press

This displays when the time was last set on the IQ System Controller (and by what means).

- Press to exit.

3 Software Version: From the Status Menu press

This displays the software version and the date it was created.

- Software Version: _____
- Press O to exit.

4 Serial Number: From the Status Menu press

This displays the IQ System Controller's serial number.

- Serial Number: _____
- Press to exit.

5 Unit Configuration: From the Status Menu press

This displays the model configuration of the IQ System Controller, set at the factory.

- Unit Configuration Code: _____
- Press to exit.

6 Model Number: From the Status Menu press

This displays the model number of the IQ System Controller.

- Model Number: _____
- Press to exit.

7 Call Sign: From the Status Menu press

This displays the call sign of the IQ System Controller.

- Call Sign: _____
- Press to exit.

8 Previous/Next: From the Status Menu press

This displays the next scheduled event. Pressing will scroll through the events in chronological order.

- Regular Events
 - Special Events
- Press to exit.

1

```
Status Menu
Configured Clock
Code=01
OK=Done
```

2

```
Status Menu
Time Last Set
2023-02-09 01:05:00A
OK=Done
```

3

```
Status Menu
Software Ver 1.00
Created 2024-05-28
OK=Done
```

4

```
Status Menu
Serial Number:
001160010000
OK=Done
```

5

```
Status Menu
Unit configuration:
0113
OK=Done
```

6

```
Status Menu
Model Number:
SSQMSTR-05N6GE
OK=Done
```

7

```
Status Menu
Call Sign:
WQFW336
OK=Done
```

8a

```
Status Menu
Next Signal:.. 2 _ 4 5 6
Event 0005: 12:00 AM
SMTWTFS OK=Done
```

8b

```
Status Menu
Next Signal:.. 2 _ 4 5 6
Event 0009: 10:01 AM
2023-02-09 OK=Done
```

Checking IQ System Controller Status Continued

9 Cap Codes: From the Status Menu press

This displays a menu to select a cap code to view:

- **IQ Time** Cap Code: _____
- **IQ Events** Cap Code: _____
- **Legacy Time** Cap Code: _____
- **Legacy Events** Cap Code: _____
- **Call Sign** Cap Code: _____
- **Other 2** Cap Code: _____
- Press  to exit.

10 Power/Transmission: From the Status Menu press . This displays:

1. **Power:** Last time power was restored to system controller
2. **Transmission:** Transmission count total and current day transmission count.

USB Update Programming

1. Insert USB drive into the bottom slot of Port A.
 - **Note:** Ensure USB drive only contains the .BIN file.
2. Enter Service Lock when prompted. Press .

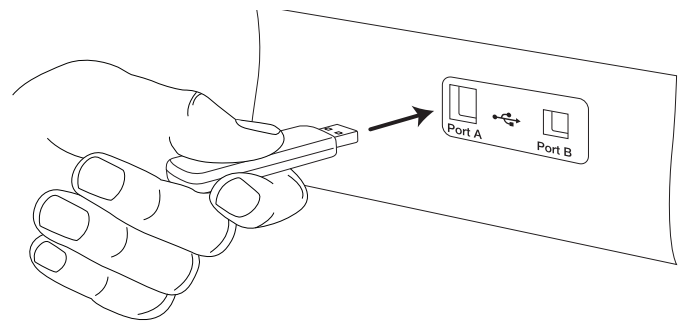

3. Press  to update software.
4. Wait approximately 4 minutes for update.

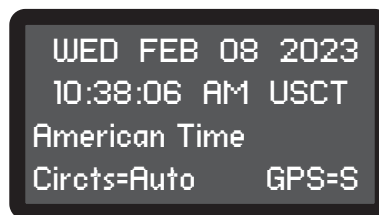
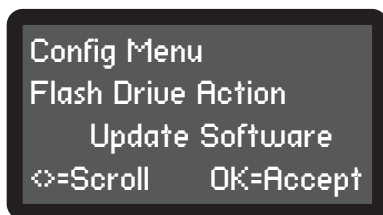

5. The Main screen is displayed when the update is complete.
 - **Note:** Latest firmware updates require version 0.5.8.15 or higher to be installed on the unit. If a version older than firmware 0.5.8.15 is on the System Controller, you will need to upgrade to firmware 0.5.8.15 first, otherwise the System Controller will not recognize the flash drive when inserted; the Update Software prompt will not be displayed. If the user attempts to manually force the firmware update through the Configuration Menu, there will be a prompt warning that the file size is too large.

Appendix G: SiteSync IQ System Controller Port Diagrams

Front of System Controller:

- A. LCD Display
- B. Keypad
- C. Port A - USB Programming Port
- D. Port B - USB Diagnostic Port

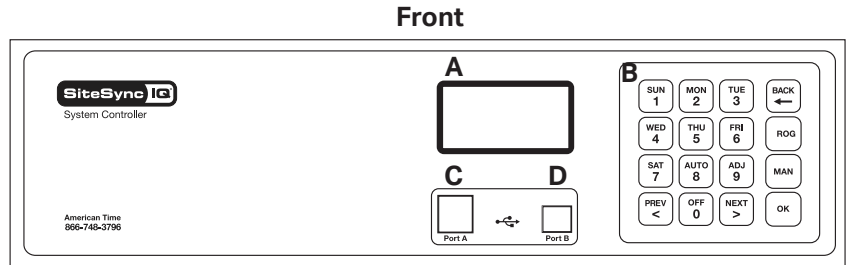

Back of System Controller:

- E. Omitted
- F. Premium GPS Antenna Port (if equipped)
- G. Transmitting Antenna Port (if equipped)
- H. Power ON/OFF Switch
- I. Omitted
- J. Power Input Port
- K. Receiver Sync RJ11 Port
- L. Ethernet RJ45 Port
- M. Contact Closure Sync Port
- N. External Transmitter Port
- O. Omitted
- P. Standard GPS RJ45 Port
- Q. Omitted
- R. Reset Switch
- S. Wiring Compartment Knockouts

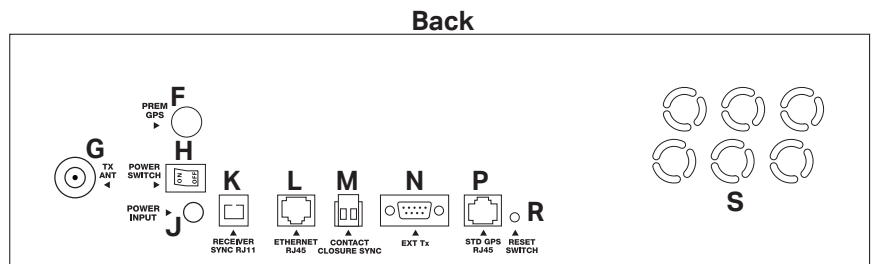

Battery powered clocks - Replace batteries

- Battery Booster 6 pack (6 alkaline, NO LONGER OFFERED) - replace every 3 1/2 years.
- Battery Booster 6 pack (6 lithium) - replace every 5 1/2 years.
- **Note:** When replacing batteries, complete the following steps to properly reset the clock:
 1. Disconnect barrel jack plug from wireless Receiver module.
 2. Remove old batteries and replace with new batteries.
 3. Connect barrel jack plug to wireless Receiver module.
 4. Watch for red flashing LED.
 5. Confirm red flashing LED begins flashing green within one minute of applying power.

Battery backup clocks - all 2.5" 6-digit digital clocks only

- Battery Maintenance:
 - The Digital Clock/Timers use a single 9vdc Ni-Cad battery rechargeable via an on board charger. This battery retains the time of day and timer counts when power is lost. If each in a series of power losses occur for a similar length of time, the battery can be conditioned to provide only that amount of backup capacity. This phenomenon is called "memory" effect. The Ni-Cad battery's "memory" can be erased by deeply discharging the battery and recharging it.
- **Note:** It is recommended that the operator remove power from the Digital Clock/Timer once per year for at least four hours.

WARNING

Replace the battery only with a 9v Ni-Cad battery. Do not replace with a regular (primary) 9v transistor battery (i.e., zinc carbon battery, alkaline battery)! An incompatible battery may leak or explode, causing equipment damage and/or personal injury! If battery must be replaced, contact American Time at 800-328-8996.

Verify wireless transmission and synchronization - Quarterly

- Confirm that TX displays on the SiteSync IQ System Controller screen near the top and/or bottom of each minute.
- Verify equipment is transmitting by resetting a clock in a known good signal area by completing the following:

Battery powered clocks:

1. Disconnect barrel jack plug from wireless Receiver module..
2. Reconnect barrel jack plug after waiting 5 seconds.
3. Watch for red flashing LED.
4. Confirm red flashing LED begins flashing green within one minute of applying power.

AC powered clocks:

1. Press and release button on back of receiver box with power applied.
2. Watch for red flashing LED.
3. Confirm red flashing LED begins flashing green within one minute of applying power.

Perform service test on battery backup/surge protector as instructed by manufacturer of unit - Annually

Keep SiteSync IQ System Controller, external transmitter (if applicable) and clocks free from dust and debris to extend service life - Annually (or as needed)

Visually inspect all system components, cables, antennas, etc. - Every 6 months (or before Daylight Saving Time changes twice per year)

Change timekeeping CR2032 battery - Every 5 years

Appendix I: Clock Circuit Wiring Diagrams

- Clock Code 01** - 3 wire Synchronous
- Clock Code 03** - Standard Electric Time Dual Motor
- Clock Code 06** - Synchronous Wired 2
- Clock Code 09** - Simplex 59th Minute Dual Motor
- Clock Code 10** - Simplex 45th Minute Dual Motor
- Clock Code 11** - National Synchronous Wired (25 sec. hour, 25 pulses 12 hour)
- Clock Code 13** - National Synchronous Wired (25 sec. hour, 25 min. 12 hour)
- Clock Code 14** - Honeywell
- Clock Code 18** - National Synchronous Wired
- Clock Code 19** - Stromberg Synchronous Wired (56th minute)
- Clock Code 20** - National Synchronous Wired (No 12 hr. correction)
- Clock Code 23** - Standard Electric Time Dual Motor (hourly correction only)
- Clock Code 36** - Synchronous Wired 2 with Noon and Midnight Sync

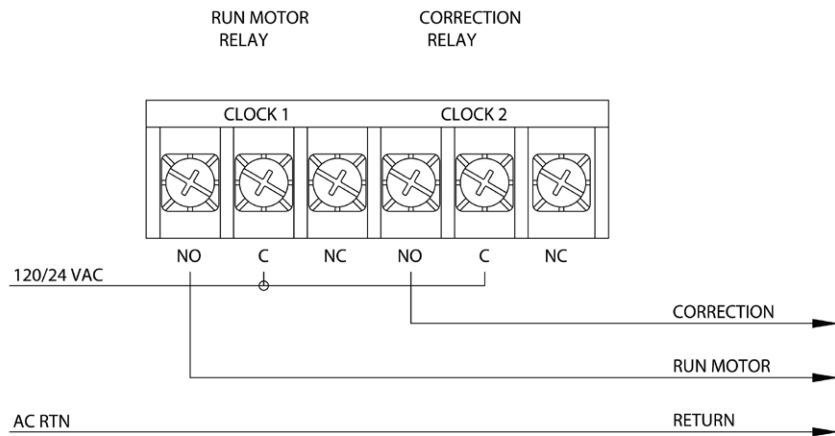

- Clock Code 02** - 3 wire Minute Impulse
- Clock Code 05** - 3 wire Minute Impulse (58th minute)
- Clock Code 16** - 3 wire Minute Impulse (59th minute) with 12hr Correction
- Clock Code 47** - Standard Electric Time AR-3 (3 wire Impulse)

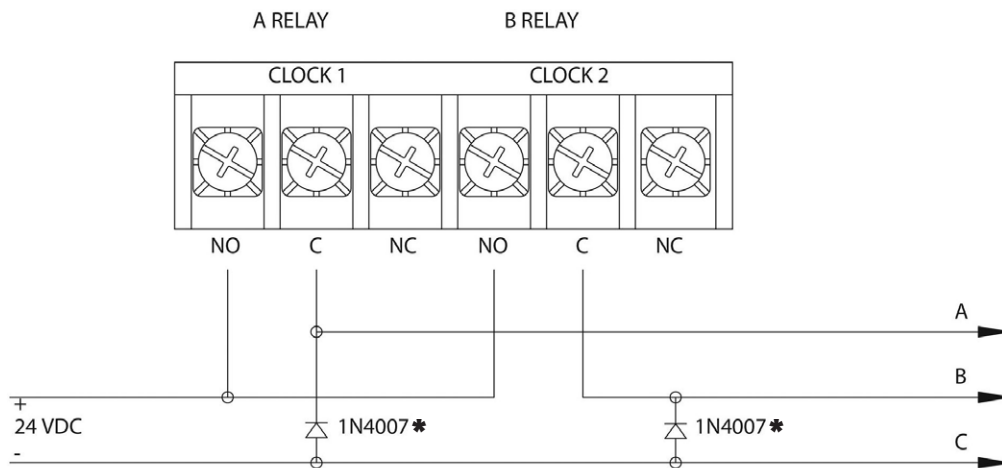

***Rectifier diodes recommended for relay protection.**

Clock Code 04 - Standard Electric Time AR-2A 2 wire Dual Voltage
 Clock Code 17 - Standard Electric Time AR-2 2 wire Dual Voltage

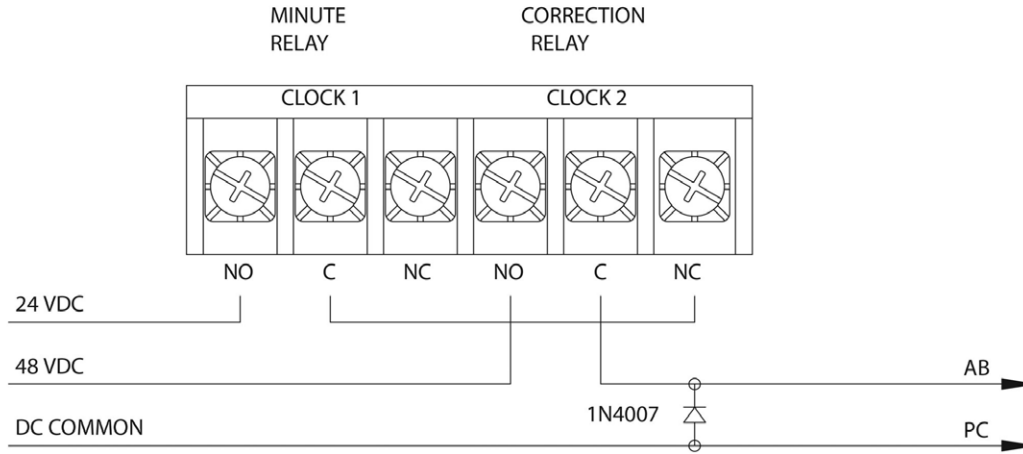

Clock Code 07 - 2 wire Reverse Polarity Minute Impulse (59th minute)
Clock Code 08 - 2 wire Reverse Polarity Minute Impulse (59th minute) with 12hr Correction
Clock Code 12 - Cincinnati D6 - 2 wire Reverse Polarity Minute Impulse (59th minute) with 12hr Correction
Clock Code 26 - Stromberg 2 wire Minute Impulse (58th minute) Hourly Correction Only

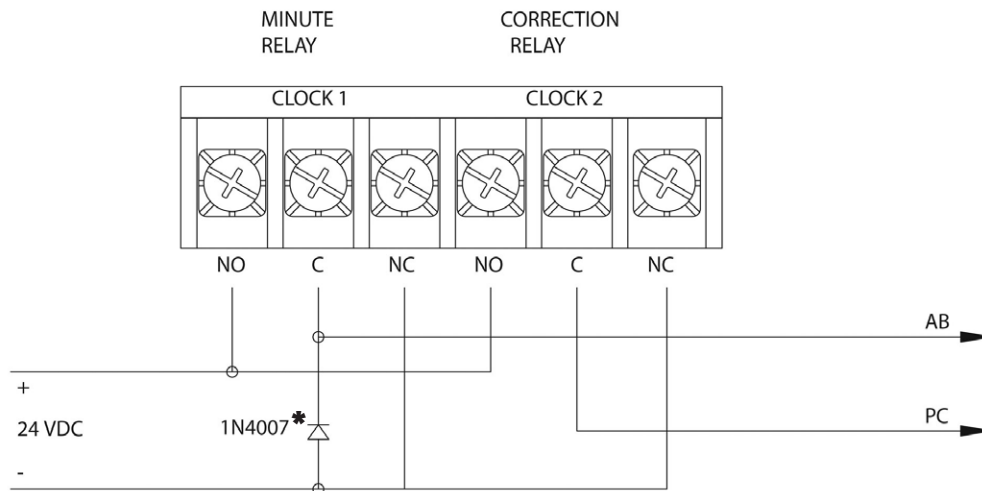

***Rectifier diode recommended for proper operation of reversing polarity.**

Appendix I: Clock Circuit Wiring Diagrams

Clock Code 15 - Straight Frequency Electronic Clock

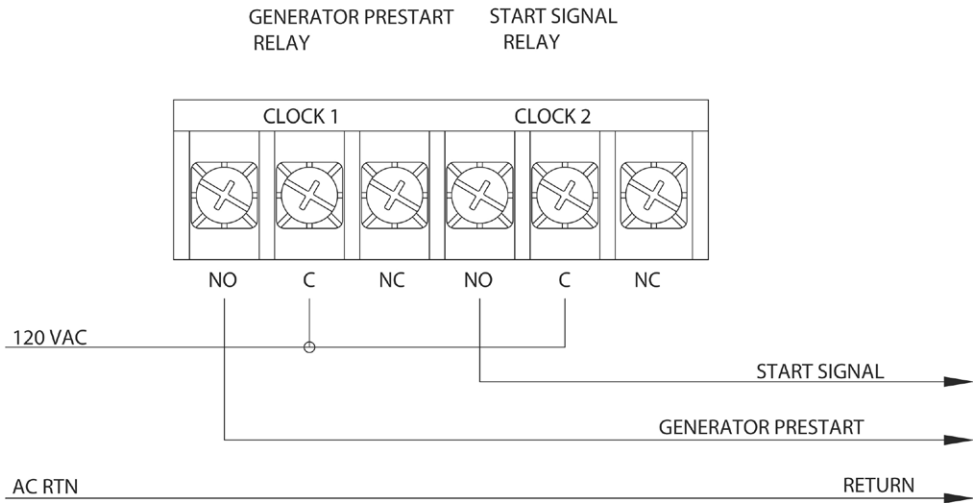

Clock Code 21 - Cincinnati D1

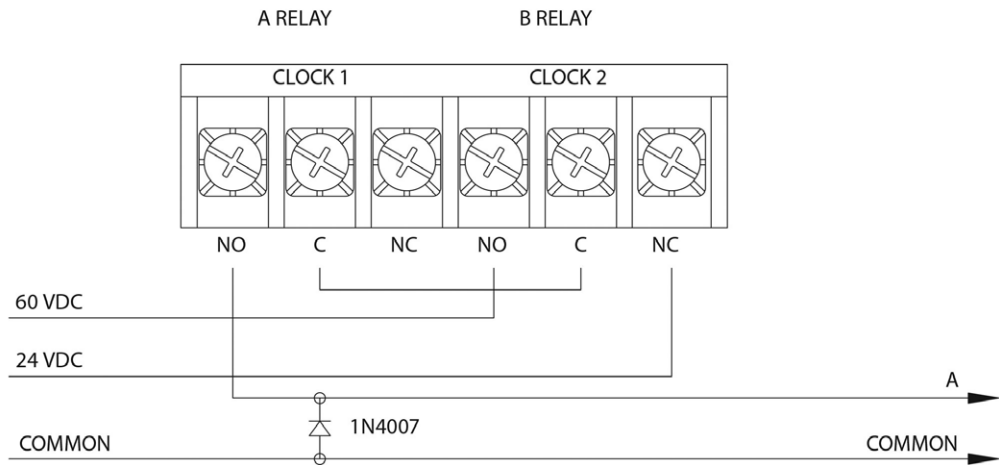

Clock Code 22 - Dukane Synchronous Wired

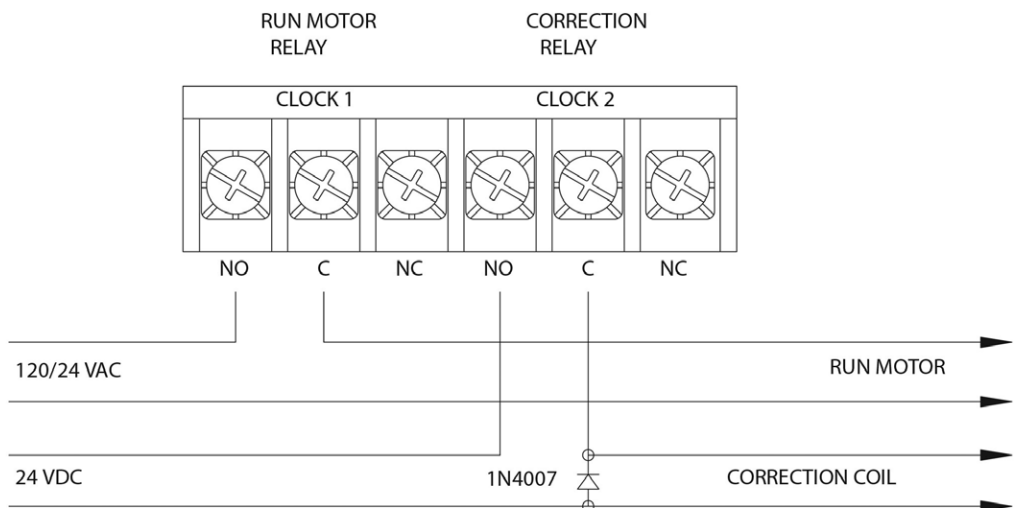

Clock Code 27 - Digital Clock Reset - 12:00 AM/PM

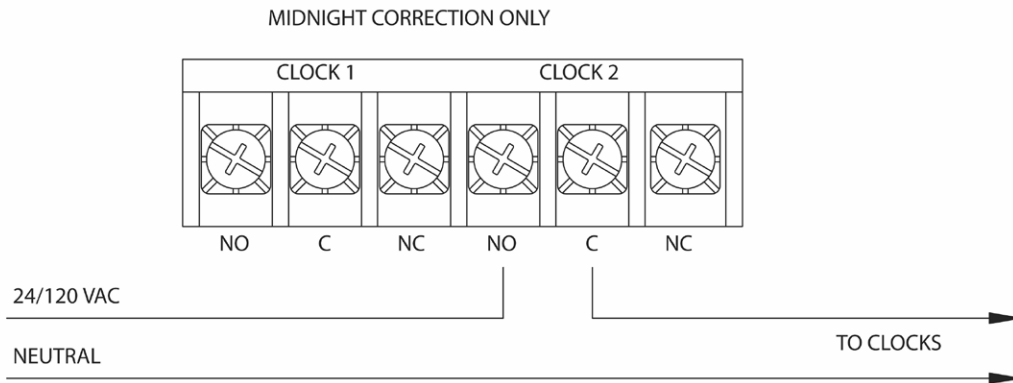
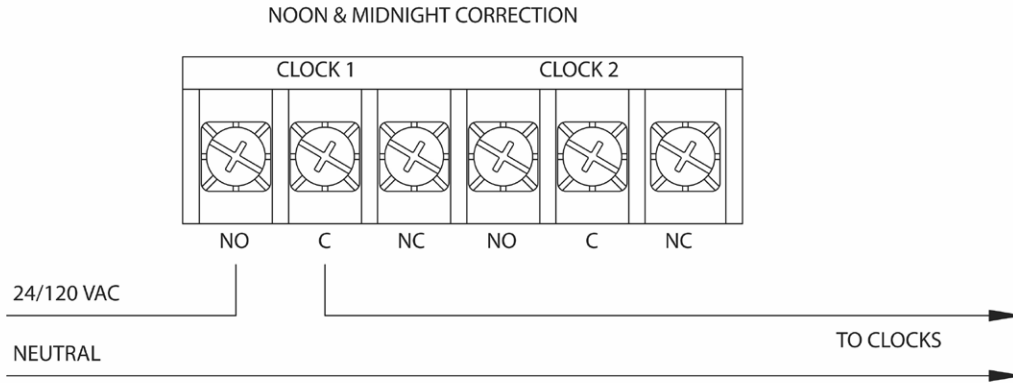

Clock Code 37 - 2 wire Reverse Polarity Minute Impulse

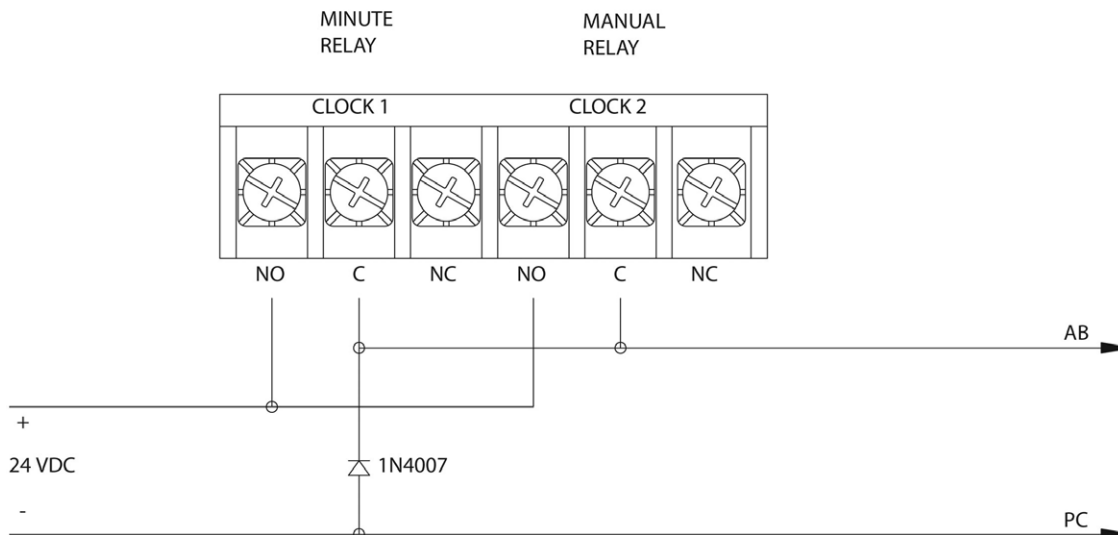

Appendix I: Clock Circuit Wiring Diagrams

Clock Code 38 - 2 wire Reverse Polarity Minute Impulse (59th minute) with 12hr Correction

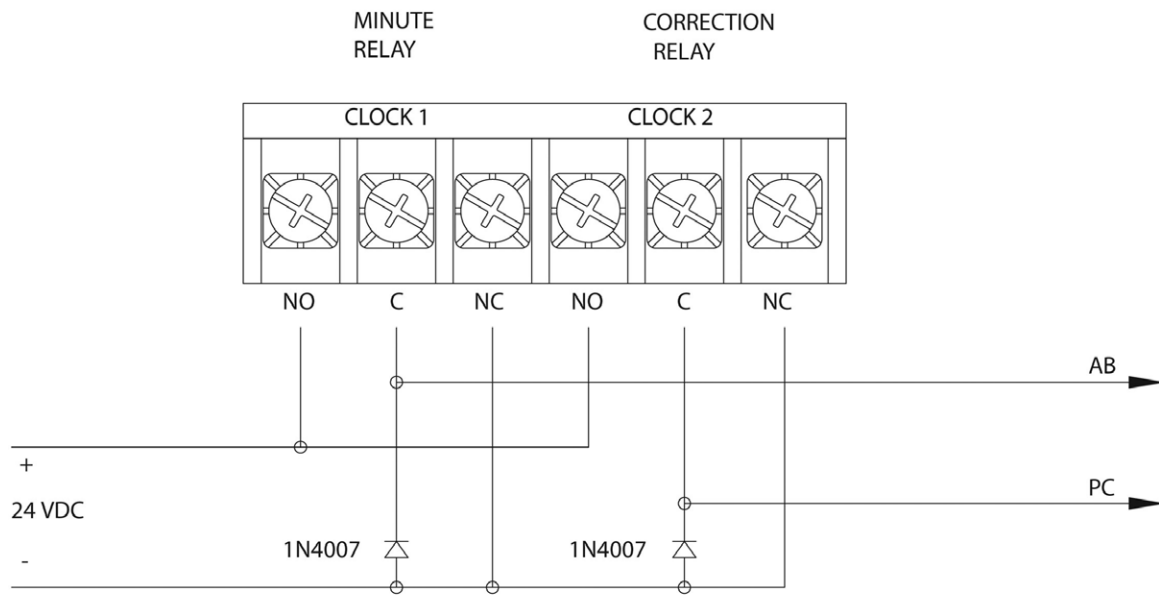

CLOCK CODE = 01

3-WIRE SYNCHRONOUS (59th MINUTE)

Hourly Correction = 8 second signal from HH:57:54 to HH:58:02

12 Hour Correction = 14 second signal from 05:57:54 to 05:58:08

Clock Types Covered:

American Time - A****(A,B or L)A***, B****(A,B or L)A***, U****(A,B or L)A***

Cincinnati - *D-10, *D-12

Dukane - 24SS* Series

Edwards - *010 & *012

Faraday/Standard Electric Time - 2315*, 2316*, 2335*, 2336*, 2370*, 2372*, 2380*, 2382* Series

IBM - 77* Series

Lathem - Type SS*

Simplex - 77* Series, 82* Series, 2310-92* Series, 6310-92* Series

CLOCK CODE = 02

3-WIRE MINUTE IMPULSE (59th MINUTE)

Every Minute from HH:59 through HH:49 - Pulse (2 sec) Between 58 and 00 Seconds (Lines A & B)

Every Minute from HH:50 through HH:58 - Pulse (2 sec) Between 58 and 00 Seconds (A LINE ONLY)

HOURLY - 59th MINUTE CORRECTION - 20 pulses between 10 and 50 seconds (Line A only)

Clock Types Covered:

American Time - A****(J or F)***, B****(J or F)***

Cincinnati - *D2, *D4

Edwards - Impulse *02, *04

Lathem - Type ISC* (3-wire hourly only correction)

Simplex/IBM - 55*, 75* & 80* Series, 6310-90* Series, 2310-90* Series

CLOCK CODE = 03

STANDARD ELECTRIC TIME DUAL MOTOR

Normal Operation - 120/24VAC continuous (RUN Only)

Hourly Correction - 29 second signal from HH:59:30 to HH:59:59 - RUN Power is Disconnected

12 Hour Correction - 15 minute signal from 5:12:00 to 5:27:00 (AM & PM) - RUN Power is Connected

Clock Types Covered:

American Time & Signal - X****(G or H)A***

Faraday - 2420 through 2431 Series

Standard Electric Time - CR & GRC 109106 through 109155, J109106 through J109155 and 105047 through 105066

CLOCK CODE = 04

STANDARD ELECTRIC TIME AR-2A TWO WIRE DUAL VOLTAGE

Every Minute - EXCEPT 59TH MIN - 24 VDC PULSE (2 SEC) FROM RUN RELAY

59th Minute - from 50 SEC to 00 SEC - HIGHER VOLTAGE (48VDC) PULSE FROM CORRECTION RELAY

Clock Types Covered:

Standard Electric Time - AR-2A

CLOCK CODE = 05

3-WIRE MINUTE IMPULSE (58th MINUTE)

Every Minute between XX:58 and XX:48 - Pulse (2 sec) Between 58 and 00 Seconds (Lines A & B)

Every Minute from XX:49 through XX:57 - Pulse (2 sec) Between 58 and 00 Seconds (Line A only)

HOURLY - 58th MINUTE CORRECTION - 20 pulses between 10 and 50 seconds (Line A only)

Clock Types Covered:

3-WIRE MINUTE IMPULSE (58th MINUTE)

CLOCK CODE = 06

SYNCHRONOUS WIRED 2

Hourly Correction - 55 second signal from HH:58:05 to HH:59:00

12 Hour Correction - 10 signals (95 sec ON, 25 sec OFF) from 05:05:00 to 05:24:35

Clock Types Covered:

American Time - H****(A or B)H***

Cincinnati - *D8, WS*

Honeywell - ST402A*

Faraday - 2310*, 2311*, 2320*, 2321*, 2330*, 2331*, 2313*, 2314*, 2333*, 2334*, and 1310 through 1431

CLOCK CODE = 07

TWO WIRE REVERSE POLARITY MINUTE IMPULSE (59th MIN)

Every Minute from HH:59:SS through HH:49:SS (at :58 to :00 SEC) - POSITIVE POLARITY (RUN RELAY)

Every Minute from HH:50:SS through HH:58:SS (at :58 to :00 SEC) - NEGATIVE POLARITY (CORRECTION RELAY)

59th Minute - 20 PULSES - NEGATIVE POLARITY (CORRECTION RELAY)

Clock Types Covered:

American Time - A****FF***, B****FF***

Lathem - Type ISC* (2-wire hourly correction only)

Cincinnati - *D3

Edwards - *03

Faraday - 2373* Series, 2383* Series

Simplex - 2310-90* Series, 6310-90* Series

CLOCK CODE = 08

TWO WIRE REVERSE POLARITY MINUTE IMPULSE (59th MIN) WITH 12 HR CORRECTION

Every Minute from XX:59:XX to XX:49:XX (at :58 to :00 SEC) - POSITIVE POLARITY (RUN RELAY)

Every Minute from XX:50:XX to XX:58:XX (at :58 to :00 SEC) - NEGATIVE POLARITY (CORRECTION RELAY)

59th Minute - 20 PULSES - NEGATIVE POLARITY (CORRECTION RELAY)

12 HOUR CORRECTION - Every Minute From 6:02:10 through 6:44:55 - 20 PULSES - NEGATIVE POLARITY

Clock Types Covered:

American Time - A****FG***

Lathem - ISC* (with 12 hour correction installed)

Note: * indicates prefix or suffix of alpha and/or numeric characters (size, shape, mounting, etc.) that are not relevant to the master clock timing protocol.

CLOCK CODE = 09

SIMPLEX 59th MINUTE DUAL MOTOR

Normal Operation - 120/24 VAC continuous (RUN only)

Hourly Correction - 54 second signal from HH:58:05 to HH:58:59 - RUN Power is Disconnected

Clock Types Covered:

Simplex - *M*

CLOCK CODE = 10

SIMPLEX 45th MINUTE DUAL MOTOR

Normal Operation - 120/24 VAC continuous (RUN only)

Hourly Correction - 54 second signal from HH:44:05 to HH:44:59 - RUN Power is Disconnected

Clock Types Covered:

SIMPLEX/IBM - *M*

CLOCK CODE = 11

RAULAND/NATIONAL SYNCHRONOUS WIRED (25 second hour, 25 pulses 12 hour)

Hourly Correction = 25 SECOND signal at first minute of every hour

12 Hour Correction - 25 signals (25 sec ON, 35 sec OFF) from 06:00:00 to 06:24:25

Clock Types Covered:

National Time - EX-HH and EX-LL

Dukane - 240* Series

Rauland - 2460 Series

CLOCK CODE = 12

CINCINNATI D6 - 2 WIRE REVERSE POLARITY MIN. IMPULSE (59th Min) W/12 HR Correction

Every Minute from XX:59:XX through XX:49:XX (at :58 to :00 SEC) - POSITIVE POLARITY and Every Minute from 4:49 to 5:55 AM&PM (at :58 to :00 SEC)

Every Minute from XX:50:XX through XX:58:XX (at :58 to :00 SEC) - NEGATIVE POLARITY ** EXCEPT from 4:49 to 5:55 AM&PM **

HOURLY CORRECTION - 59th Minute - 20 PULSES - NEGATIVE POLARITY

12 HOUR CORRECTION - Every Minute From 5:00:10 through 5:30:50 - 20 PULSES - NEGATIVE POLARITY

Clock Types Covered:

American Time - B***FG***

Cincinnati - *D6

Edwards - *06

Faraday - 2376*, 2386*

CLOCK CODE = 13

RAULAND/NATIONAL SYNCHRONOUS WIRED (25 second hour, 25 min 12 hour)

Hourly Correction = 25 SECOND signal at first minute of every hour

12 Hour Correction = 25 MINUTE signal from 6:00:00 to 6:25:00

Clock Types Covered:

National Time - EX-HH and EX-LL

Dukane - 240* Series

Rauland - 2460 Series

CLOCK CODE = 14

HONEYWELL

Hourly Correction - 55 second signal from HH:58:05 to HH:59:00

12 Hour Correction - 12 signals (65 sec ON, 25 sec OFF) from 05:05:00 to 05:22:35

Clock Types Covered:

American Time - H****(A or B)H***

Cincinnati - *D8, WS*

Honeywell - ST402A*

Faraday - 2310*, 2311*, 2320*, 2321*, 2330*, 2331*, 2313*, 2314*, 2333*, 2334*, and 1310 through 1431

CLOCK CODE = 15

STRAIGHT FREQUENCY ELECTRONIC CLOCK

PREP: Every Hour from HH:57:00 to HH:59:00 - 2 Minute Signal on GENERATOR PRESTART Line

HOURLY CORRECTION: Every Hour (except 5) from HH:57:54 to HH:58:02 - 8 Second Signal on START SIGNAL Line

12 HOUR CORRECTION: From 5:57:54 to 5:58:08 - 14 Second Signal on START SIGNAL Line

Clock Types Covered:

Simplex/IBM

CLOCK CODE = 16

3-WIRE MINUTE IMPULSE (59th MINUTE) W/12 HR CORRECTION

Every Minute from XX:59 through XX:49 - Pulse (2 sec) Between 58 and 00 Seconds (Lines A & B)

Every Minute from XX:50 through XX:58 - Pulse (2 sec) Between 58 and 00 Seconds (A LINE ONLY)

HOURLY - 59th MINUTE CORRECTION - 20 pulses between 10 and 50 seconds

12 HOUR CORRECTION - Every Minute From 6:02:10 through 6:44:55 - 20 PULSES

Clock Types Covered:

American Time - A***JG***

Lathem - Type ISC* (3-wire with 12 Hour correction)

CLOCK CODE = 17

STANDARD ELECTRIC TIME AR-2 TWO WIRE DUAL VOLTAGE

Every Minute - EXCEPT 58TH MIN - 24 VDC PULSE FOR 2 SEC

58th Minute - from 58:50 to 59:00 - HIGHER VOLTAGE (48VDC) PULSE

Clock Types Covered:

Standard Electric Time - AR-2

CLOCK CODE = 18

NATIONAL SYNCHRONOUS WIRED

Hourly Correction = 28 SECOND signal at first minute of every hour

12 Hour Correction = 27 MINUTE signal from 6:00:00 to 6:27:00

Clock Types Covered:

American Time - G Series

National Time - EX-HH and EX-LL

Dukane - 240* Series

Rauland - 2460 Series

Note: * indicates prefix or suffix of alpha and/or numeric characters (size, shape, mounting, etc.) that are not relevant to the master clock timing protocol.

CLOCK CODE = 19

STROMBERG SYNCHRONOUS WIRED (56th MINUTE)

Hourly Correction = 8 second signal from HH:56:10 to HH:56:18**12 Hour Correction** = 14 second signal from 11:56:36 to 11:56:50**Clock Types Covered:**

Stromberg - WX*

CLOCK CODE = 20

NATIONAL SYNCHRONOUS WIRED (NO 12 HR CORRECTION)

Hourly Correction = 28 SECOND signal at first minute of every hour

12 Hour Correction = NONE

Clock Types Covered:

National Time

CLOCK CODE = 21

CINCINNATI D1

2nd THROUGH 58TH MINUTE - 24 VDC PULSE FOR 2 SEC**59th THROUGH 1st MINUTE** - 60 VDC PULSE FOR 2 SEC**HOURLY CORRECTION** - HH:59:10 to HH:01:49 - THREE SETS OF TWENTY PULSES (24VDC)**Clock Types Covered:**

Cincinnati - *D1

CLOCK CODE = 22

DUKANE SYNCHRONOUS WIRED

Hourly Correction = 55 second signal from HH:57:00 to HH:57:55**12 Hour Correction** = 11 signals - 55 sec ON, 65 sec OFF at 5:59:00 AM & PM**Clock Types Covered:**

Dukane - 24A*, 24B*, 24C*, 24D*, and 24E* Series

CLOCK CODE = 23

STANDARD ELECTRIC TIME DUAL MOTOR (HOURLY CORRECTION ONLY)

Normal Operation - 120/24 VAC continuous (RUN only)**Hourly Correction** - 29 second signal from HH:59:30 to HH:59:59 - RUN Power is Disconnected**Clock Types Covered:**

Standard Electric Time

CLOCK CODE = 25

INDUSTRIAL ELECTRONIC SERVICE MASTER CLOCK (DIGITAL CLOCKS)

NORMAL OPERATION - Black Wire 24 VDC Positive with Respect to White Wire**MINUTE RESET** - Secondary Clocks Advance 2 Minutes per Second of Polarity Reversal**12 HOUR RESET** - Power is removed from the Secondary Clocks at 11:59:57 AM and PM for 3 Seconds**Clock Types Covered:**

Industrial Electronic Service - TBD

CLOCK CODE = 26

STROMBERG 2 WIRE MINUTE IMPULSE (58th MINUTE, HOURLY CORRECTION ONLY)

Every Minute from XX:06:XX through XX:57:XX (at :58 to :00 SEC) - NEGATIVE POLARITY**Every Minute** from XX:58:XX through XX:05:XX (at :58 to :00 SEC) - POSITIVE POLARITY**58th Minute** - From XX:58:10 to XX:58:50 - 20 PULSES - NEGATIVE POLARITY**12 HOUR CORRECTION** - NONE**Clock Types Covered:**

Stromberg

CLOCK CODE = 27

DIGITAL CLOCK RESET - 12:00 AM/PM

NORMAL OPERATION - RELAYS CLOSED - 24/120VAC TO SECONDARY CLOCKS**12 HR CORRECTION** - RESET AT 12:00 AM (and PM, for Noon versions)**CLOCK CODE = 36**

SYNCHRONOUS WIRED 2, WITH NOON & MIDNIGHT SYNC

Hourly Correction = 55 second signal from HH:58:05 to HH:59:00**12 Hour Correction** - 10 signals (95 sec ON, 25 sec OFF) from 05:05:00 to 05:24:35**CLOCK CODE = 37**

TWO WIRE NONCORRECTIVE MINUTE IMPULSE

Every Minute - XX:XX:58 through XX:XX:00 - POSITIVE POLARITY**CLOCK CODE = 38**

TWO WIRE REVERSE POLARITY MINUTE IMPULSE (59th MIN) WITH 12 HR CORRECTION

Every Minute from XX:59:XX to XX:49:XX (at :59 to :00 SEC) - POSITIVE POLARITY**Every Minute** from XX:50:XX to XX:58:XX (at :59 to :00 SEC) - NEGATIVE POLARITY**HOURLY CORRECTION** - 59th Minute - 24 PULSES - NEGATIVE POLARITY from HH:59:02 through HH:59:48**12 HOUR CORRECTION** - Each Minute from 6:01:02 through 6:39:48 - 24 PULSES - NEGATIVE POLARITY**Clock Types Covered:**

American Time - A****FG***

Lathem - ISC* (with 12 hour correction installed)

Note: * indicates prefix or suffix of alpha and/or numeric characters (size, shape, mounting, etc.) that are not relevant to the master clock timing protocol.

Quiet Mode is a feature that will reduce the number of transmissions of your system controller. This will decrease the likelihood of interfering with other equipment while increasing the life of the transmitter.

If Quiet Mode is enabled (reference page 45), the system controller will reduce the number of transmissions after 24 hours of normal operation. This will allow time to install clocks during the initial system installation. After the initial 24 hours, Quiet Mode will be designated on the main time display as follows:



After the initial 24 hours, the system controller will be in Quiet Mode. This mode can be disabled for 6 hours by pressing **TUE 3** - **THU 5** - **SAT 7** on the keypad. This will allow for installing additional clocks or changing the batteries on clocks. However, it is not necessary to turn off Quiet Mode to correct the clocks. The clocks will correct automatically between the hours of 12:00:00 AM and 6:00:00 AM if they are off time.

Quiet Mode may be forced On by pressing **SUN 1** - **WED 4** - **FRI 6** when on the main time screen. This will allow for turning Quiet Mode On immediately in the event of a power outage instead of waiting 24 hours for the system to reset.

Glossary

Analog Clock - A clock that represents time by position of hands on a dial.

CAT 5 Cable - Category 5 Cable. A twisted pair cable type designed for high signal integrity and commonly used in computer networks such as Ethernet. CAT 5 cable is used for GPS extension cables and Ethernet wiring in the SiteSync IQ System.

Circuit - One of the 6 relay outputs on the SiteSync IQ System Controller.

Client - A computer or other networked device, or a software application, that connects to and request information from a server.

Contact Closure Sync - A common method of synchronizing two devices together by means of a 2-wire connection. The output device provides a synchronization time pulse once per day at a specified time by closing the connection on the 2-wires leading to the input device.

Daytime Protocol (RFC-867) - A standard, Internet-based timekeeping specification that calls for a timestamp to be sent from a timeserver as an ASCII character string containing the current date and time. This message is sent from the timeserver as a response to any input on port 13. The timeserver closes the connection as soon as the timestamp is sent. The SiteSync IQ System Controller is capable of sending and receiving timestamps via UDP port 13 using this protocol.

DHCP - The Dynamic Host Configuration Protocol (DHCP) is an auto configuration protocol used on IP networks. A DHCP server can automatically assign an IP address to the Sitesync IQ system controller when DHCP is enabled.

Digital Clock - A clock that displays time with numerical display (12:00).

Ethernet - A very popular technology for networking computers

and other devices. This communication method is used for transmitting and receiving precise timing signals by the SiteSync IQ System Controller.

Event - Programmed into the SiteSync IQ System Controller with time and date information, as well as a duration or a start/stop command. For example, Event 0001 may be programmed to execute every Monday, Wednesday and Friday at 10:00 am for 3 seconds.

FCC - Federal Communication Commission. A U.S. government agency in charge of regulating non-federal government use of radio spectrum.

Firewall - A network configuration, usually both hardware and software, that forms a fortress between networked computers within an organization and those outside the organization. It is commonly used to protect information such as e-mail and data files within a physical building or organization site.

Gateway - A network device or network point that acts as an entrance to another network, such as the server through which computers on a local area network (LAN) access the Internet.

Gateway IP Address - The address value for the Gateway device on the network (see Gateway).

GPS - Global Positioning System. A constellation of satellites operated by the United States Military (US Naval Observatory) that broadcast precisely timed signals from space. These signals are used for extremely accurate global navigation as well as the distribution of precise time.

Internet - A worldwide system of computer networks in which any one computer can get information from/or talk to any other connected computer using the TCP/IP protocols.

Leap Second - A second of time as measured by an atomic clock, added to or omitted from official timekeeping systems annually to

compensate for changes in the rotation of the earth.

Low-E glass - Low Emissivity Glass. This type of glass features a unique surface coating that reduces the heat transfer through the window. Such a coating can reflect anywhere from 40% to 70% of the normally transmitted heat, while not inhibiting the amount of light that passes through the window. However, the metal oxide coating of Low-E glass does not allow the GPS signals to pass through. Thus, mounting the GPS antenna inside a window with Low-E glass is not recommended.

Master Clock - In a timekeeping or clock system, a device that acts as the source of time. The Master Clock, or System Controller, transmits the time to any number of secondary (slave) clocks.

Navigation Message - A message, transmitted by each GPS satellite, containing its orbital elements, clock behavior, system time and status messages.

Network - A group of interconnected computers or other electronic devices, capable of transferring data signals with each other.

NIST - National Institute of Standards and Technology. The Time and Frequency Division, part of NIST's Physics Laboratory, maintains the standard for frequency and time interval for the United States and provides official time to the United States. This includes traceability from the GPS timing signals to the NIST national frequency standard.

Patch Cable - A cable with plugs or terminals on each end of the conductor or conductors used to connect circuits of equipment together. Patch cables are used to connect an individual computer or other device to a network. The SiteSync IQ System Controller can be connected to an RJ-45 jack with an Ethernet Patch Cable.

RJ-45 - Registered Jack-45. An 8-pin (or 8-wire) modular connector used to attach data transmission devices to standard telephone wiring. Commonly used in Ethernet data connections and installed in the SiteSync IQ System Controller for physical connection of the Ethernet port.

RS-422 - Standard communications interface approved by the Electronic Industries Alliance (EIA) for connecting serial devices and supporting multi-point connections. This interface supports higher data rates and higher immunity from interference than RS-232 and is used for communication between the SiteSync IQ System Controller and the Premium GPS receiver.

Schedule - A group of events. For example, a school might program Schedule 01 with 4 events for their morning Elementary recess schedule. The SiteSync IQ System Controller allows for 99 unique schedules, with any number of events in each (up to a maximum total of 9,999 events).

Secondary Clock - Also known as a slave clock. This is a clock that synchronizes its timekeeping to that of a system master clock.

Server - A host computer or host device on a network, which shares resources and "serves" data to client computers or other servers.

Shrink Tubing - Tubing which has been extruded, cross-linked and mechanically expanded which, when reheated, will return to its original diameter. For this GPS kit, it is used to protect the electrical and communications connections from water, etc. It can be easily installed over the connectors and will shrink tightly over them after being heated.

SNTP - Simple Network Time Protocol. A less complex form of Network Time Protocol (NTP) commonly used for synchronization of computers and other devices. In SNTP, the client makes a single timing request to a single server (similar to the Daytime Protocol) and then uses this information to set its clock. This differs from NTP, which uses multiple servers and averages their results. The SiteSync IQ System controller supports SNTP as both a client and a server.

Static IP Address - An Internet Protocol (network) address permanently assigned to an individual machine, account or user.

Subnet Mask - A number that helps to define the relationship between the host (computers, routers, switches, etc.) and the rest of the network.

Synchronization - The process of bringing two clocks or time sources into phase so their difference is zero. In the case of a timekeeping system, time synchronization takes place between the master clock and all secondary clocks. In addition, in the case of the GPS timekeeping option, the SiteSync IQ System Controller is synchronized to the GPS time source so the time output of the master is matched to the NIST time standard.

Timeserver - A system or device that acquires the correct time from a local reference clock and/or remote timeservers and will answer time requests from other systems. See "Server" above.

Timeserver IP Address - The value of an address for a timekeeping server on the local computer network or Public Internet.

Timestamp - A time mark or notation that indicates the date and time.

UDP - User Datagram Protocol. An Ethernet protocol commonly used for time sensitive applications and which does not guarantee reliability, but does not delay packets (as in TCP-IP).

UL - Underwriters Laboratory. U.S. non-profit safety testing and certification organization.

USNO - U.S. Naval Observatory. An organization within the United States Navy which determines precise time and maintains the master clock for the United States. The USNO monitors the timing of the Global Positioning System (GPS) to provide a reliable and stable coordinated time reference for the GPS satellite navigation system.

UTC - Universal Coordinated Time. A time-scale that forms the basis of a coordinated distribution of standard frequencies and time signals throughout the world. It is often referred to as Greenwich Mean Time (GMT) or Zulu Time (military and aviation).

American Time
140 3rd Street South, PO Box 707
Dassel, MN 55325-0707

Phone: 800-328-8996
Fax: 800-789-1882

american-time.com