

Wiring Connections and Ring Installation (cont'd)

2-Wire 24V Wiring (Wi-Fi and SiteSync IQ 24V Clocks)

1. Strip ends of plug wires as necessary.
2. Pass the ends of the wires through the hole in the mounting ring base and mounting plate.
3. Make connections between the facility wiring and the clock wiring with provided wire nuts (hot to hot [black], neutral to neutral [white]) as shown below.
4. Attach the mounting plate to the electrical box (screws not included).
5. Mount the ring base to the mounting plate with the provided acorn nuts.

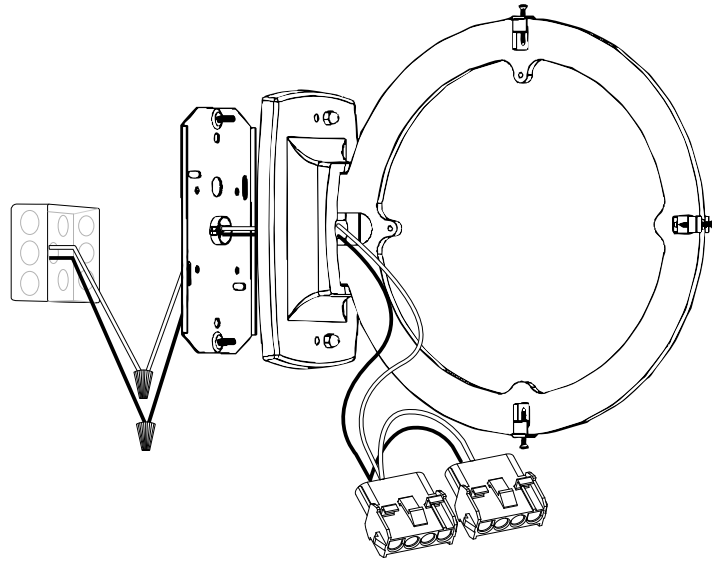

2-Wire Impulse Wiring (Impulse Clocks Only)

1. Strip ends of plug wires as necessary.
2. Pass the ends of the wires through the hole in the mounting ring base and mounting plate.
3. Make connections between the facility wiring and the clock wiring with provided wire nuts (PC to PC [white] and AB to AB [red]) as shown.
4. Attach the mounting plate to the electrical box (screws not included).
5. Mount the ring base to the mounting plate with the provided acorn nuts.

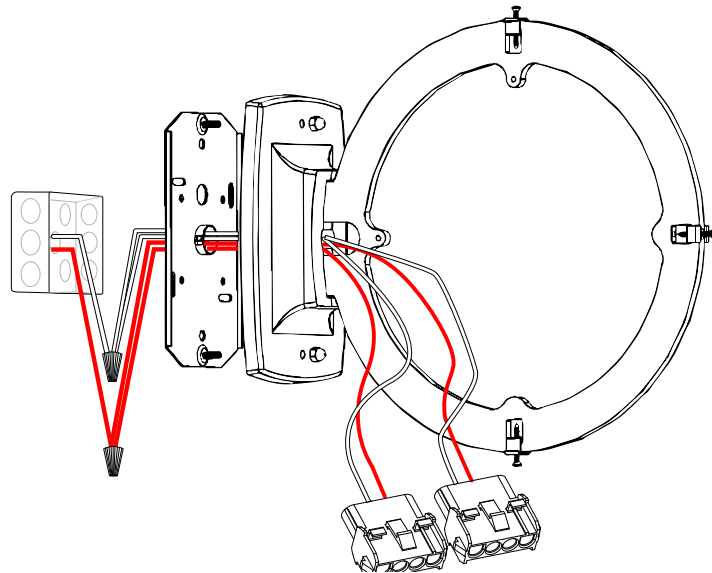

No Wiring (PoE and All Battery-Powered Clocks)

1. (PoE clocks only) Pass two Ethernet cables through the center hole in the mounting ring base and mounting plate.
2. Attach the mounting plate to the electrical box (screws not included).
3. Mount the ring base to the mounting plate with the provided acorn nuts.

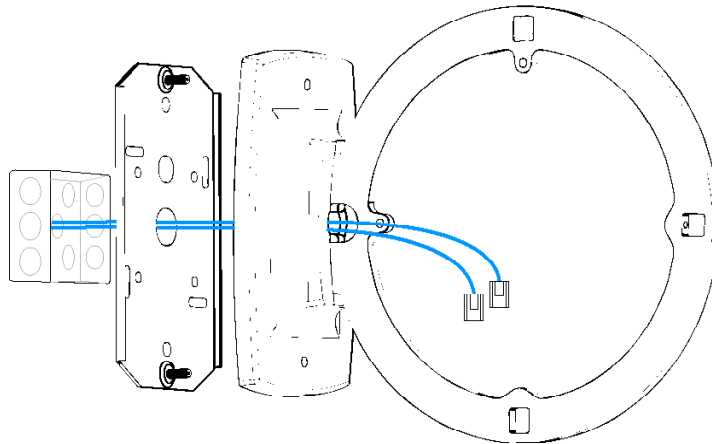

Steel Double-Dial Clock Mounting Ring Installation Quick Start



Read this first!

Ensure electrical boxes at the site(s) of installation are properly secured to the wall/ceiling framing prior to mounting clocks.

If this is your first installation or you have questions at any time during this process, please call American Time at **800-328-8996**.

Box Contents

Double-Dial Ring

1. Mounting Plate
2. Double-Dial Base and Ring
3. Wire harness (not included with PoE or battery-powered clocks)

Hardware Kit (KIT-2369A)

1. 10-24 x 1 1/2" mounting screws (2)
2. Acorn nuts (2)
3. Retainer clips (3)
4. #6 x 1 1/4" retainer screws (3)
5. Nylon bushing (1)

NOTE: These instructions apply only to the installation of the mounting ring and any necessary wiring. Instructions for installing clocks to the ring are provided in the individual clock boxes.

american  time.

phone: 800-328-8996

online: american-time.com

fax: 800-789-1882

QUICK START INSTALLATION GUIDE

1

Mounting Plate Installation and Ring Assembly

1. Install the nylon bushing into the larger center hole in the mounting plate from the side opposite the threaded studs.

NOTE: The bushing is not necessary for PoE clocks.

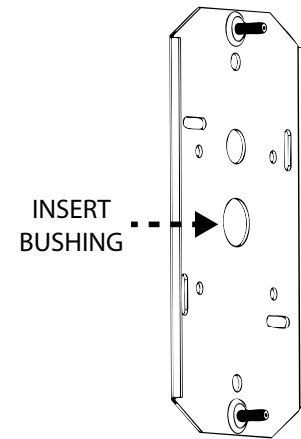

2. Install the 1 1/2" mounting screws in the appropriate mounting lug in the ring. Thread the screws halfway into the lug from opposite sides. For wall mount clocks, the lug 90 degrees from the base should be used. For ceiling mount clocks, the lug directly above the base should be used.

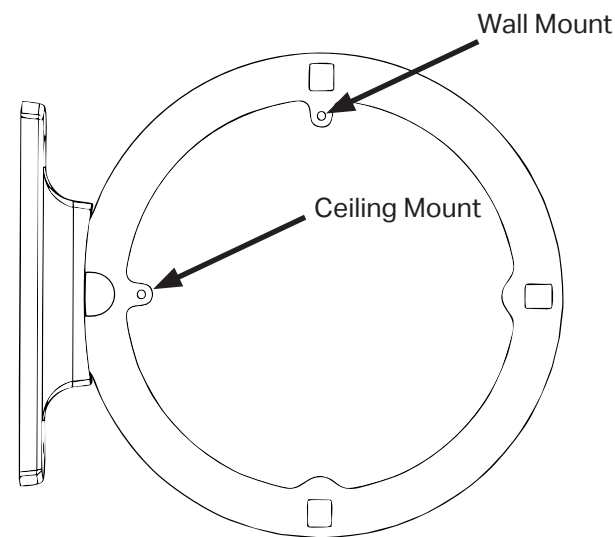

3. Insert the retainer clips into the cutouts in the ring as shown and start the 1 1/4" retainer screws, leaving them loose until the clocks are installed. The flanges on the clips should be oriented toward the outside of the ring.

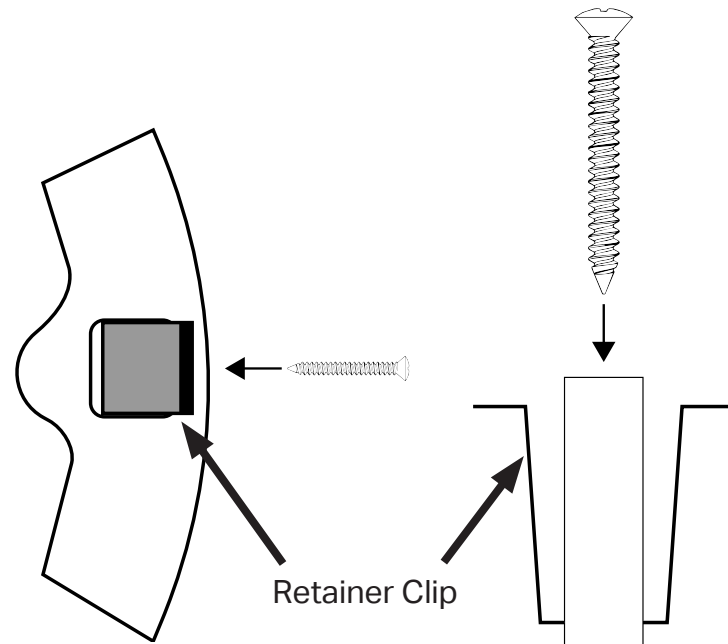

STEEL DOUBLE-DIAL CLOCK MOUNTING RING

2

Wiring Connections and Ring Installation

NOTE: Wiring will vary depending on clock model - find the option to match your clock below.

2-Prong 120VAC Wiring (Wi-Fi, SiteSync, and AllSet 120VAC clocks)

1. Strip ends of plug wires as necessary.
2. Pass the ends of the wires through the hole in the mounting ring base and mounting plate.
3. Make connections between the facility wiring and the clock wiring with provided wire nuts (hot to hot, neutral to neutral) as shown below.
4. Attach the mounting plate to the electrical box (screws not included).
5. Mount the ring base to the mounting plate with the provided acorn nuts.

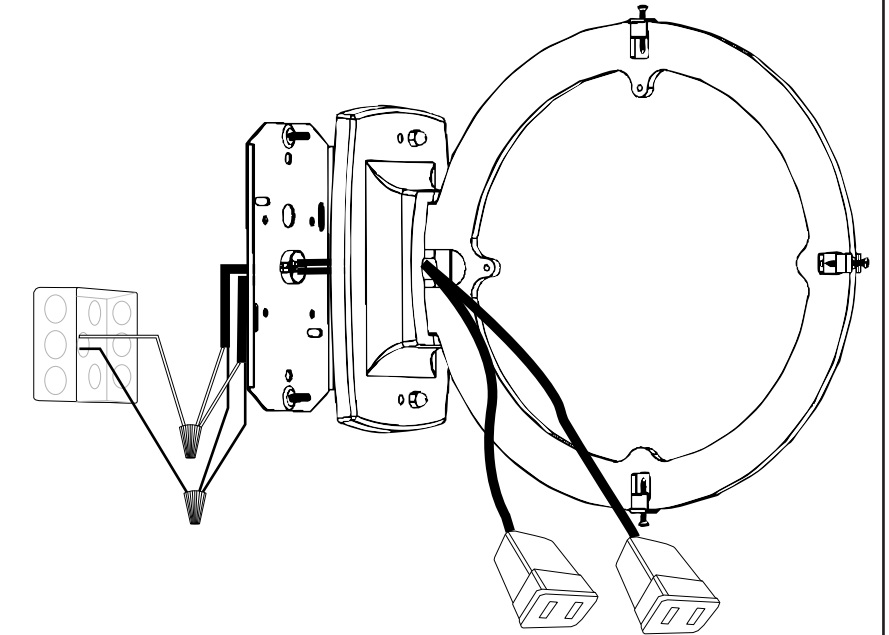

3-Wire 120VAC Wiring (AllSync and Mechanical Clocks)

1. Strip ends of plug wires as necessary.
2. Pass the ends of the wires through the hole in the mounting ring base and mounting plate. The knotted wire must stay on the inside of the ring to maintain applicable UL certification.
3. Make connections between the facility wiring and the clock wiring with provided wire nuts (hot to hot [black], neutral to neutral [white], correction [red] to correction) as shown.
4. Connect ground terminals to earth ground.
5. Attach the mounting plate to the electrical box (screws not included).
6. Mount the ring base to the mounting plate with the provided acorn nuts.

