

6

Activating Clocks on the inCloud Portal

To easily activate your clocks on the inCloud Management portal, download American Time's Network Clocks mobile app for Android devices (see QR code provided below).



Scan the QR code to the left to download the Network Clocks mobile app. The app allows you to quickly and easily set up clocks on inCloud.

Scan the QR code to the right to access the quickstart guide for the Network Clocks mobile app.



If clocks can only be activated using a computer, follow the steps listed below.

1. Navigate to the inCloud portal: incloud.american-time.com. Log in using the credentials supplied in the welcome e-mail from American Time.
2. Click on the green "Setup New" button in the PoE Devices bar on the Devices List page. This will open the Activate Network Devices page, which will list all the clocks assigned to your site by American Time.
3. Click the MAC address.
 - If you have multiple devices to set up, the MAC address can be searched using the last five characters of the address including the colon (for example, AA:11) in the search bar.
4. Reference the MAC Address Log Sheet from Step 5 for the installation location and enter the location in the Device Title field.

If you have additional clocks to set up, repeat Steps 3 and 4 until your setup is complete. Once you have finished setting up clocks, clicking on "Devices" in the sidebar menu will take you back to the Devices List page. After activation, clocks will appear as partially activated in the Devices List until they communicate with inCloud fully; this may take up to one hour, but clocks will function normally until that occurs.

Power over Ethernet (PoE) Analog Steel Double-Dial Clocks



Please read this first!

If this is your first installation or you have questions at any time during this process, please call American Time at **800-328-8996**.

1

Pre-Installation

1. Verify network infrastructure with Network Administrator.
 - Power over Ethernet (PoE) solution
 - Dynamic Host Configuration Protocol (DHCP) settings

2

Unpack the box

- Remove the components from the box. Save the packing materials in case you need them later. If the double-dial ring has not already been mounted, refer to the instructions provided in the double-dial ring kit for mounting installations, then return to these instructions to mount the clocks.

3

Check the contents

Your package contains:

1. Analog PoE clock(s)
2. Quick Start Guide
3. Installation and Operation Manual (1 per shipment)
4. MAC Address Log Sheet (1 per shipment)
5. USB Drive (optional) with Network Clock Connect Software—Part #H004167B-POE

NOTE FOR NON-INCLOUD CUSTOMERS: If you have not purchased a subscription to the inCloud Management Portal, setup is complete after step 5. See back page to learn more.



phone: 800-328-8996

online: american-time.com

fax: 800-789-1882

QUICK START INSTALLATION GUIDE

4

Set up the Clock

1. Apply power to the clocks by connecting Cat 5 or higher Ethernet cables (A) from a PoE switch (Fig. 1) to the PoE receivers (D). The cables should have already been run through the double-dial mounting ring during the installation of the ring.
 - PoE Switch - Check with network administrator for infrastructure needs. This part is not supplied by American Time.
2. The status LED (B) will indicate the clocks' statuses as follows:
 - Flashing Red: Acquiring an IP address using DHCP
 - Continuous Red: Acquired IP address
 - Flashing Orange: Attempting SNTP sync
 - Continuous Green: Successful SNTP sync

Following the IP connection and SNTP sync, inCloud-connected clocks will communicate with the management portal. During this communication period, the LED will flash green.

3. The buzzer LED (C) designates if the buzzer is enabled. The buzzer is an optional feature.

Note: When a DHCP network is not present at initial start up, the PoE clocks will default to a random Static IP in the range of 169.254.1.0 to 169.254.254.255.

For more details reference the PoE Devices Installation & Operation Manual at click.american-time.com/PoE-Manual

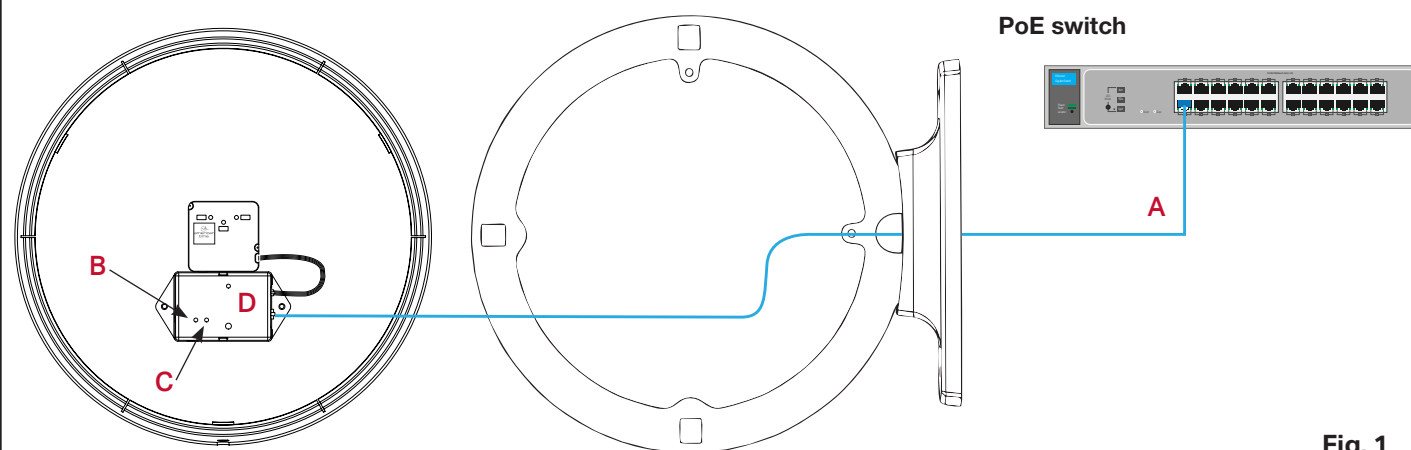

Fig. 1

A=PoE connection (Cat 5 or higher Ethernet patch cable)

B=Status LED C=Buzzer LED D=PoE Receiver

POWER OVER ETHERNET ANALOG CLOCKS

5

Hang your clocks

1. Before mounting the clocks, find the MAC address for the clocks on the included MAC address log sheet and note the location of the clocks (i.e. room number) for future reference. The clock MAC address is located on the back of each clock.
2. Place the hanger on the back of the clocks on the screws protruding from the top lug on the double-dial ring as shown below. Wall-mount installation is pictured; for ceiling-mount clocks, the mounting ring will be rotated 90 degrees and the protruding screws will be in the lug nearest the mounting ring base.
3. Tighten the screws on the edge of the double-dial ring to secure the clocks in place as shown below.

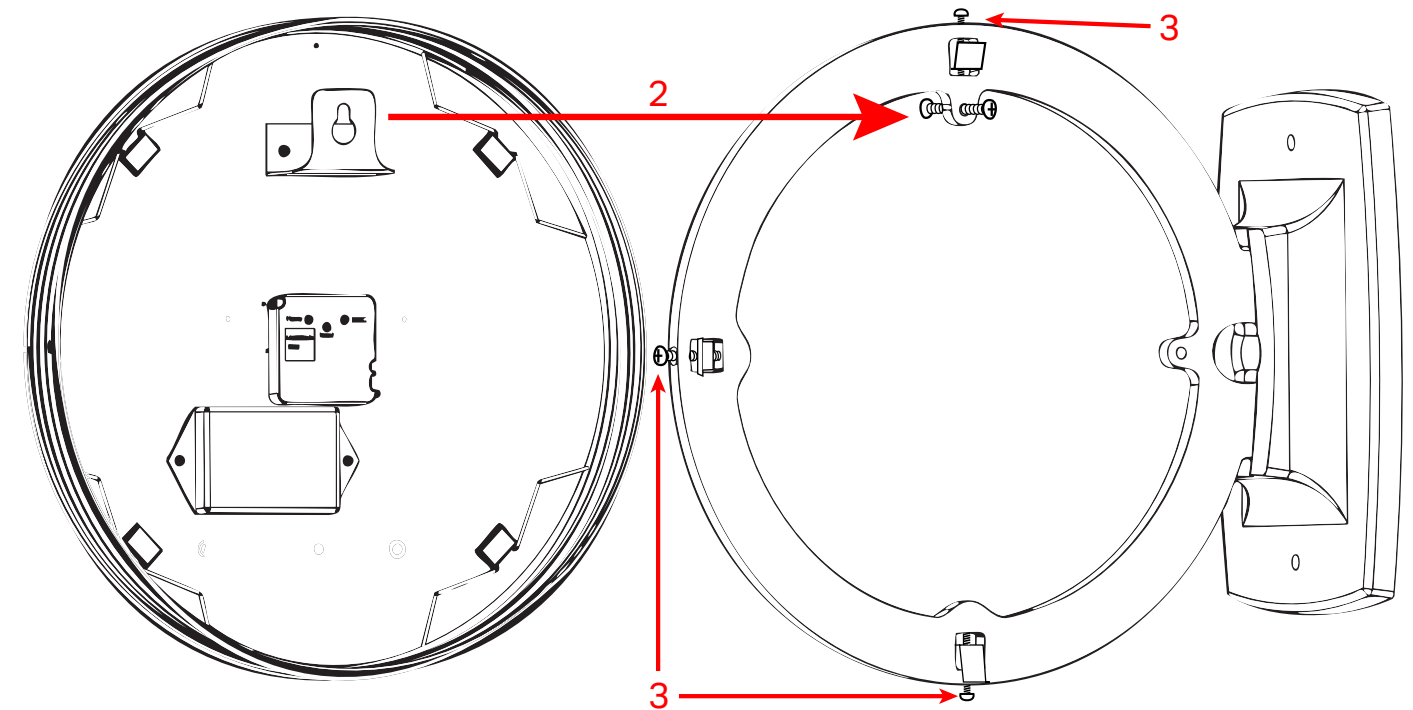

inCloud users should progress to Step 6 (back page).

If you have not purchased a subscription to the inCloud Management Portal, installation is now complete. For additional configuration options for customers not using the inCloud Management Portal, download the Network Clock Connect application at <https://click.american-time.com/nccddownload> (Windows only)



The inCloud Management Portal is a cloud-based platform to enhance and simplify management of your clock system.

Features include remote monitoring of clock status, configuration adjustment, scheduled event management, and more.

To learn more, visit click.american-time.com/incloud or scan the QR code:

